

HIDRA CRONO Controller

Programming Manual Version 8.0



DC81080Q01



ENGLISH

How to use the manual

Each parameter is described as follows:

XX.XX.XX - Parameter name

Parameter description (*The description may include allowable values and notes*)

EXAMPLE: *Represents a possible situation*

FACTORY DEFAULT: *Default parameters*

MIN: *Minimum value (X)*

MAX: *Maximum value (XX)*

STEP: *Increase (X)*

Access Level
(Level required to view or change the parameter)

Device
(Device required to view or change the parameter)

Connection Location
(Location to connect device)

Example

02.02.01.03 - Close door attempts

Sets the number of door close attempts before entering blocked door mode

FACTORY DEFAULT: 10

MIN: 10

MAX: 20

STEP: 1

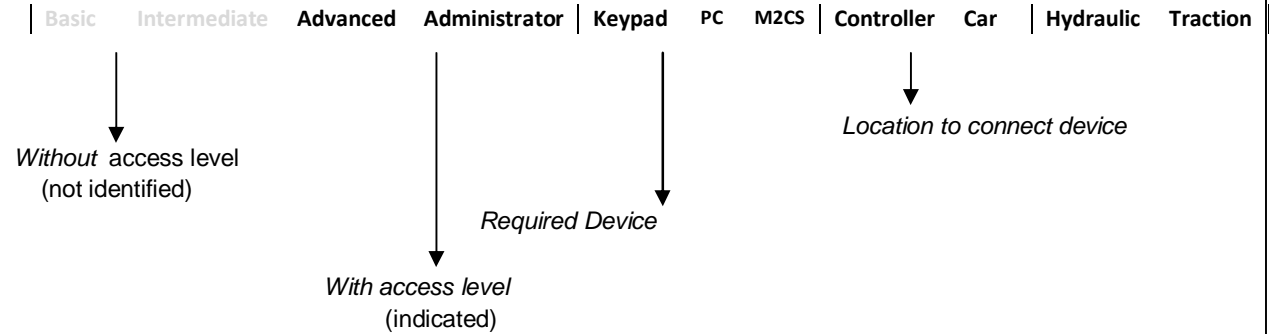

01 - MONITOR	10
01.01 - STATUS	10
01.02 - SUB STATUS	10
01.03 - FAULT REASON.....	10
01.04 - MACHINE STATUS	10
01.05 - MACHINE SUB STATUS	10
01.09 - POSITION MONITOR	10
01.09.01 - Actual floor.....	10
01.09.02 – Destination floor.....	10
01.09.04 – Magnet number.....	10
01.09.05 – Magnet zone identifier.....	10
01.12 - SPS MONITOR	11
01.12.01 - Level.....	11
01.12.02 - SPS programmed	11
01.12.03 - SPS consistent.....	11
01.12.04 - SPS and encoder communication established	11
01.12.10 - SPS lift speed	11
01.12.20 - SPS offset	11
01.12.21 - SPS level of the last speed change.....	11
01.12.30 - SPS minimum braking distance	11
01.12.75 - SPS firmware version	11
01.13 - SPS2 MONITOR	12
01.13.01 - Level.....	12
01.13.02 - SPS programmed	12
01.13.04 - SPS and encoder communication established	12
01.13.10 - SPS lift speed	12
01.13.75 - SPS firmware version	12
01.14 - OUTPUTS MONITOR	12
01.14.01 - Direction signals	12
01.14.02 - Speed signals.....	12
01.15 - INPUTS MONITOR	12
01.15.01 - Series monitor	12
01.15.02 - Position monitor.....	12
01.15.03 - Brake contacts monitor.....	13
01.15.04 - Speed governor blocking contact monitor	13
01.15.05 - CPE monitor.....	13
01.15.11 - Car disable monitor	13
01.15.11.01 - Car disable signals monitor	13
01.15.17 - Automatic entering under inspection	13
01.15.17.01 - Shaft access detection signal.....	13
01.15.20 – VIP signal monitor.....	13
01.15.50 - Door control signals monitor.....	13
01.15.51 - Photocell monitor.....	13
01.15.52 – Monitor of door 1 & door 2 fully opened signals	14
01.15.60 – Overload sensor monitor.....	14
01.15.65 – Hydraulic drive signals	14
01.15.73 – EN81-73 monitor	14
01.15.73.01 - Monitor of main & alternative alarm signals.....	14
01.50 - COUNTERS MONITOR	14
01.50.01 – Car calls for door 1.....	14
01.50.02 – Car calls for door 2.....	14
01.50.03 – Upward calls for door 1.....	14
01.50.04 – Upward calls for door 2.....	14
01.50.05 – Downward calls for door 1	15
01.50.06 – Downward calls for door 2	15
01.50.07 – Automatic calls	15
01.50.50 - Trip counter.....	15
01.50.51 - Minutes of operation	15
01.50.52 - Total amount of working hours.....	15
01.50.70 - CANC errors (%).....	15
01.60 - EVENTS LOG	15
01.60.01 - 01.60.32 From Event number 1 to Event number 32	15
01.70 - HARDWARE MONITOR	15

01.70.01 - Controller interface communication bus.....	15
01.70.10 - Shaft CAN.....	16
01.70.20 - Car CAN.....	16
01.70.30 - COP1 communication bus.....	16
01.70.31 - COP2 communication bus.....	16
01.70.40 - SAR communication bus.....	16
01.70.90 - Micro SD.....	16
02 - CONFIGURATION	17
02.01 - MAIN PARAMETERS	17
02.01.02 - Top floor.....	17
02.01.03 – Main access floor stoppage time.....	17
02.01.04 – Floor Stoppage time.....	17
02.01.06 - Assembly period mode.....	17
02.01.07 - Under inspection stops on CV signals	17
02.01.08 - Positioning mode.....	17
02.01.09 - SPS model.....	18
02.01.10 - Non collective operation.....	18
02.02 - DOORS	18
02.02.01 - Doors global parameters	18
02.02.01.01 - CAM.....	18
02.02.01.02 - Door close time limit.....	18
02.02.01.03 - Close door attempts	18
02.02.01.04 - Blocked door timer.....	18
02.02.01.05 - Time to quit blocked door mode	19
02.02.01.06 - Reopening due to a landing call.....	19
02.02.01.07 - Photocell attempts	19
02.02.01.08 - Time to set doors on rest mode	19
02.02.01.09 - Maximum time allowed, while running, with door series open.....	19
02.02.01.10 - Doors speech synthesis.....	19
02.02.01. 30 - Out for the retiring ramp.....	19
02.02.02 - Floor dependent door parameters.....	20
02.02.02.01 - 02.02.02.32 From Floor 0 door configuration to Floor 31 door configuration.....	20
02.02.03 - Advanced door opening.....	20
02.02.03.01 - Advanced door opening enable.....	20
02.02.03.02 - Point of advanced door opening	20
02.02.05 - Behavior in case of photocell block.....	20
02.02.50 - Inputs and outputs of door operators.....	20
02.02.50.01 - Output signal for close door 1 under reduced power	21
02.02.50.02 - Output signal for close door 2 under reduced power	21
02.02.50.10 - Input for the door closed signal.....	21
02.02.50.20 - Input for the signal of door operator temperature.....	21
02.03 - INDICATIONS	21
02.03.01 - Direction arrows.....	21
02.03.02 - Display	21
02.03.02.01 - 02.03.02.32 From Floor 0 display symbol to Floor 31 display symbol.....	21
02.03.03 - Acoustic.....	22
02.03.03.01 - 02.03.03.32 From Floor 0 speech synthesis to Floor 31 speech synthesis.....	23
02.03.04 - Car here light.....	24
02.03.04.01 - Car here light enable.....	24
02.03.04.02 - 02.03.04.33 From Car here light for floor 0 to Car here light for floor 31	24
02.03.05 - Show double symbols on displays.....	25
02.03.07 - Car GONG mode of operation	25
02.03.10 - LCD text.....	25
02.03.20 - Acoustic indication of door opened	25
02.03.25 – Auxiliary output for overload indication.....	25
02.03.30 – Car light lit indication.....	25
02.03.40 – Fire alarm indication	25
02.03.80 – Under public service indication.....	26
02.03.81 – Out of service indication.....	26
02.03.82 – Under inspection indication.....	26
02.03.85 – Idle indication	26
02.03.86 – Lift going up indication.....	26
02.03.87 – Lift going down indication.....	26
02.03.88 – Trip indication.....	26

02.03.90 – Doors opened indication	26
02.03.91 – Doors closed indication	26
02.04 - CAR HOMING AND AUTOMATIC CALLS	26
02.04.01 - Homing	26
02.04.01.01 - Return enable.....	26
02.04.01.02 - Homing floor	27
02.04.01.03 - Return timer.....	27
02.04.02 - Basement return.....	27
02.04.02.01 - Basement return enable	27
02.04.02.02 - Basement return floor	27
02.04.02.03 - Basement return timer	27
02.04.03 - Car Disable	27
02.04.03.01 - Input signal for car disable 1	27
02.04.03.02 - Floor to park on disable 1 signal.....	28
02.04.03.11 - Input signal for car disable 2	28
02.04.03.12 - Floor to park on disable 2 signal.....	28
02.04.05 - Doors opening when automatic returns	28
02.04.10 - Leveling.....	28
02.04.10.01 - Leveling enable.....	28
02.05 - DRIVE TYPE PARAMETERS.....	28
02.05.10 - Control type.....	28
02.05.11 - Demagnetizing time	28
02.05.50 - Motor configuration	29
02.05.50.01 - Selection of direct start or star-delta start.....	29
02.05.50.10 - Star time	29
02.05.50.20 - Time between star and delta.....	29
02.05.60 - Motor disconnection delay.....	29
02.05.65 - Speed signals connection delay after motor	29
02.05.70 - Valve block.....	29
02.05.80 - Safety valve test	29
02.08.80.01 - Safety valve test enable	29
02.08.80.05 - Do the safety valve test just now.....	30
02.08.80.10 - Time between safety valve tests	30
02.08.80.20 - Valve opening time.....	30
02.06 - LOW CONSUMPTION (ENERGY EFFICIENCY).....	30
02.06.01 - Car light	30
02.06.01.01 - Car light timer	30
02.06.01.02 - Turn off car light only with door closed	30
02.06.02 - Call acceptance light brightness.....	30
02.06.03 - Time to set displays to a low consumption mode.....	30
02.07 - RESCUES	30
02.07.10 - Rescue mode	31
02.07.20 – Automatic, unbalanced rescue	31
02.07.20.01 - Signal to allow the automatic rescue by unbalance.....	31
02.07.30 – Automatic, at low speed, to most favourable floor	31
02.07.30.01 - When the lift is going up the inverter indicates.....	31
02.07.35 – Automatic rescue to a extreme floor.....	31
02.07.35.01 - Rescue to a bottom or top floor	31
02.07.40 - Defined floor rescue.....	32
02.07.40.01 - Rescue floor	32
02.07.40.02 - Always rescue to the defined floor.....	32
02.07.45 - Hydraulic rescue	32
02.07.45.01 - Rescue to the lowest floor	32
02.08 – CAR RESTRICTION.....	32
02.08.01 - Temporal call restrictions.....	32
02.08.02 - Input for disable all calls	32
02.08.10 - Auxiliar input to set out of service	32
02.08.30 - Floor restrictions.....	33
02.08.30.01 - 02.08.30.23 -restrictions floor 0 – floor 22	33
02.10 - SPECIFIC OPTIONS OF THE INSTALLATION.....	33
02.10.01 - Evacuation control in case of fire (EN81-73).....	33
02.10.01.01 - EN81-73 operative.....	33
02.10.01.02 - Main evacuation floor.....	33
02.10.01.03 - Door to open on main evacuation floor.....	33
02.10.01.04 - Main alarm signal	33

02.10.01.05 - Do not enter sign on main evacuation floor	33
02.10.01.06 - Alternative evacuation floor.....	34
02.10.01.07 - Door to open on alternative evacuation floor	34
02.10.01.08 - Alternative alarm signal	34
02.10.01.09 - Do not enter sign on alternative evacuation floor	34
02.10.01.20 - Close doors at evacuation floor	34
02.10.01.21 - VIP enabled in case or alarm	34
02.10.05 - EN81-20 cotrol.....	34
02.10.05.01 - Enable EN81-20	34
02.10.05.10 - Output to indicate movement with chain bridged.....	35
02.10.10 - Control of the speed governor blocking system (A3)	35
02.10.10.01 - Speed governor blocking system	35
02.10.10.02 - Speed governor unlocked signal.....	35
02.10.10.03 - Speed governor unlocking control.....	35
02.10.10.04 - Maximum number of errors allowed on speed governor blocking system	35
02.10.11 - Brake contacts Monitor system (A3).....	35
02.10.11.01 - Brake contacts Monitors enable.....	35
02.10.11.02 - Brake contact 1 (1 of 2).....	36
02.10.11.03 - Brake contact 2 (2 of 2).....	36
02.10.11.04 - Maximum number of errors allowed on brake monitor.....	36
02.10.15 - Function of automatic entering Inspection Mode	36
02.10.15.01 - Enable the automatic entering under Inspection	36
02.10.15.02 - Signal to detect shaft access	36
02.10.15.04 - Permission to leave Inspection Mode.....	36
02.10.15.10 - Resume normal operation after inspection.....	36
02.10.15.11 - Signal to detect shaft access	37
02.10.15.12 - Resume normal operation after inspection.....	37
02.12 - SPS CONFIGURATION	37
02.12.01 – Floor distribution	37
02.12.10 – Encoder model.....	37
02.12.11 – Encoder direction.....	37
02.12.20 – Lift nominal speed.....	37
02.12.21 – Machine nominal speed	37
02.12.30 – Inverter type.....	37
02.12.31 – FUJI parameters.....	38
02.12.31.01 – L19 parameter	38
02.12.31.02 – L24 parameter	38
02.12.31.03 – L25 parameter	38
02.12.31.04 – L26 parameter	38
02.12.31.05 – E12 parameter.....	38
02.12.31.06 – E13 parameter.....	38
02.12.32 – Control Techniques parameters.....	38
02.12.32.01 – 1914/A35 parameter.....	39
02.12.32.02 – 1915/A36, A37, A38 parameter	39
02.12.32.03 – 0211/A40 parameter.....	39
02.12.32.04 – 0221/A41 parameter.....	39
02.12.50 – Advanced configuration	39
02.12.50.01 – ZD magnet correction	39
02.12.50.16 – Distance required for movement detection	39
02.12.50.17 – Short floor distance.....	39
02.12.50.25 – short floors speed change adjustment factor	39
02.12.50.30 – Speed change adjustment factor	40
02.12.50.35 – Percentage of overspeed allowed on deceleration.....	40
02.13 – SPS2 CONFIGURATION	40
02.13.01 – Floor distribution	40
02.13.10 – Floors adjustment	40
02.13.10.01 - 02.13.10.32 Level of floor 0 to Level of floor31	40
02.13.20 – floor zone distances	40
02.13.20.01 - advanced door opening distance.....	40
02.13.20.10 - Distance required to stop going down.....	40
02.13.20.15 - Distance required to stop going up.....	41
02.13.40 – Smax settings	41
02.13.40.01 - Smax speed	41
02.13.40.10 - UP dec. Smax.....	41
02.13.40.11 - DOWN dec. Smax.....	41
02.13.40.20 - Up acc. Smax	41
02.13.40.21 - DOWN acc. Smax.....	41

02.13.40.90 - Smax disable	41
02.13.41 – Smed settings	41
02.13.41.01 - Smed speed.....	41
02.13.41.10 - UP dec. Smed	41
02.13.41.11 - DOWN dec. Smed	42
02.13.41.20 - Up acc. Smed.....	42
02.13.41.21 - DOWN acc. Smed.....	42
02.13.41.90 - Smed disable	42
02.13.42 – Smin settings	42
02.13.42.01 -Smin speed.....	42
02.13.42.10 -UP dec. Smin	42
02.13.42.11 -DOWN dec. Smin.....	42
02.13.42.20 -Up acc. Smin.....	42
02.13.42.21 -DOWN acc. Smin	42
02.13.42.90 -Smin disable	42
02.13.90 – SPS2 advanced parameters	43
02.15 - MAINTENANCE	43
02.15.01 - Test	43
02.15.01.01 - Test mode enable	43
02.15.01.02 - Test mode behavior	43
02.15.01.03 - Doors operation under test mode	43
02.15.01.04 - Waiting time between test travels	43
02.15.05 - Speed governor test.....	43
02.15.05.01 - Output for the coil 1	43
02.15.05.02 - Coil 1 pulse.....	44
02.15.05.03 - Output for the coil 2	44
02.15.05.04 - Coil 2 pulse.....	44
02.15.05.05 - Output for the coil 3	44
02.15.05.06 - Coil 3 pulse.....	44
02.15.10 - Final limit switch test.....	44
02.15.15 - UCM test.....	44
02.15.15.01 - UCM test upwards.....	44
02.15.15.10 - UCM test downwards	44
02.15.20 - Brake test.....	45
02.15.20.01 - Brake test command.....	45
02.20 - ADVANCED PARAMETERS	45
02.20.01 - Run time limit while on public service.....	45
02.20.02 - Series filter	45
02.20.03 - Machine room temperature sensor enabled.....	45
02.20.04 - Minimum environment temperature allowed	45
02.20.05 - Maximum environment temperature allowed	45
02.20.07 - Photocell configuration.....	45
02.20.08 - Overload detector configuration	46
02.20.09 - False calls cancelling.....	46
02.20.10 - Magnets Table.....	46
02.20.10.01 - 02.20.10.32 From Floor 0 magnet data to Floor 31 magnet data	46
02.20.15 - Machine temperature sensor enabled (PTC).....	47
02.20.16 - CAN fault tolerant mode	47
02.20.20 - SSG broken requires manual restart	47
02.20.21 – Automatic leaving of inspection mode.....	47
02.25 - GROUP	47
02.25.01 – Maximum number of lifts allowed in group	47
02.25.02 – Car identification	47
02.25.10 - Number of floors of the group.....	47
02.25.11 - Number of floors of this car	47
02.25.12 - Number of bottom floors not served	48
02.25.13 - Number of top floors not served.....	48
02.25.20 - Group behavior.....	48
02.25.21 - Car typology.....	48
02.40 - CAR TOP SIGNALS	48
02.40.01 – Inspection Mode door open Pushbutton	48
02.40.02 - Inspection Mode door close Pushbutton	48
02.40.03 – Auxiliary input for full load signal	48
02.40.04 – Auxiliary input for overload signal	49
02.40.50 - Signal to disable false alarm calls.....	49

02.41 - SHAFT SIGNALS	49
02.41.01 - Final limit switch signal.....	49
02.50 - VIRTUAL CABLES	49
02.50.01 - 02.50.32 From Virtual cable 0 to Virtual cable 31	49
02.60 - LOG CONFIGURATION	49
02.60.01 - Store the positioning information into the log	49
02.60.02 - Save the series status onto the LOG	49
02.75 - USER ADMINISTRATION	49
02.75.01 - User 1.....	50
02.75.01.01 - PIN number	50
02.75.01.02 - Access level	50
02.75.02 - User 2.....	50
02.75.02.01 - PIN number	50
02.75.02.02 - Access level	50
02.75.03 - User 3.....	50
02.75.03.01 - PIN number	50
02.75.03.02 - Access level	51
02.75.04 - User 4.....	51
02.75.04.01 - PIN number	51
02.75.04.02 - Access level	51
02.75.05 - User 5.....	51
02.75.05.01 - PIN number	51
02.75.05.02 - Access level	51
02.75.90 - Administrator.....	51
02.75.90.01 - PIN number	52
03 - TOOLS.....	53
03.01 - RESTART	53
03.02 – FLOOR CALL	53
03.05 - PARTIAL TRIP COUNTER	53
03.05.01 - Partial trip counter value	53
03.05.02 - Partial trip counter reset.....	53
03.12 - SPS UTILITIES	53
03.12.05 - Lower floor correction force.....	53
03.12.10 - Learn installation.....	53
03.12.20 - Floor level fine adjust.....	53
03.12.30 - Floors adjustment.....	54
03.12.30.01 – 03.12.30.32 Lever of floor 0 to level of floor 31.....	54
03.12.35 - Zone Adjustment	54
03.12.35.01 – 03.12.35.32 Floor 0 zone adjust to floor 31 zone adjust.....	54
03.12.40 - SPS parameters save.....	54
03.12.90 - SPS factory defaults.....	54
03.13 – SPS2 UTILITIES.....	54
03.13.10 - Learn installation.....	54
03.13.11 - speed learning.....	54
03.13.40 - SPS parameters save.....	55
03.13.90 - SPS factory defaults.....	55
03.50 - DATE AND TIME	55
03.50.01 - Week day	55
03.50.02 - Year.....	55
03.50.03 - Month	55
03.50.04 - Day	55
03.50.05 - Hour.....	56
03.50.06 - Minute	56
03.55 - PARAMETERS.....	56
03.55.01 - Save parameters.....	56
03.55.10 - Restore factory defaults.....	56
03.55.90 - Optional features access.....	56
03.60 – FAULT HISTORY	56
03.60.01 – Fault history reset.....	56
03.90 - UPGRADE	56
03.90.01 - Upgrade Controller Firmware	57
ANNEXES AND EXAMPLES.....	58
ANNEX 1. INPUTS AND OUTPUTS AVAILABLE FOR HIDRA CRONO	58

MANUFACTURER'S NOTE:

Carlos Silva SA will accept no liability for claims concerning damage or costs derived from non-fulfilment of the indications of this manual, or giving a use beyond what is described here.

The information contained in this document may change without warning. Except for that allowed under the copyright laws, all reproduction, adaptation or translation is prohibited without written permission.

@Carlos Silva is a registered trademark of *Carlos Silva S.A.*

HIDRAsystem is a product owned by *Carlos Silva S.A.*

HIDRA CRONO is a product owned by *Carlos Silva S.A.*

01 - Monitor

Allows checking of the lift status

01.01 - Status

Shows car status in real time

| **Basic** **Intermediate** **Advanced** **Administrator** | keypad **PC** **M2CS** | **Controller** **Car** | **Hydraulic** **Traction** |

01.02 - Sub status

Shows car sub status in real time

| **Basic** **Intermediate** **Advanced** **Administrator** | keypad **PC** **M2CS** | **Controller** **Car** | **Hydraulic** **Traction** |

01.03 - Fault reason

Shows car fault reason in real time

| **Basic** **Intermediate** **Advanced** **Administrator** | keypad **PC** **M2CS** | **Controller** **Car** | **Hydraulic** **Traction** |

01.04 - Machine status

Shows machine status in real time

| **Basic** **Intermediate** **Advanced** **Administrator** | keypad **PC** **M2CS** | **Controller** **Car** | **Hydraulic** **Traction** |

01.05 - Machine sub status

Shows machine sub status in real time

| **Basic** **Intermediate** **Advanced** **Administrator** | keypad **PC** **M2CS** | **Controller** **Car** | **Hydraulic** **Traction** |

01.09 - Position monitor

Shows car position monitor in real time

| **Basic** **Intermediate** **Advanced** **Administrator** | keypad **PC** **M2CS** | **Controller** **Car** | **Hydraulic** **Traction** |

01.09.01 - Actual floor

Shows the floor where the car is at

| **Basic** **Intermediate** **Advanced** **Administrator** | keypad **PC** **M2CS** | **Controller** **Car** | **Hydraulic** **Traction** |

01.09.02 - Destination floor

Shows the floor where the car is going to

| **Basic** **Intermediate** **Advanced** **Administrator** | keypad **PC** **M2CS** | **Controller** **Car** | **Hydraulic** **Traction** |

01.09.04 - Magnet number

Shows the magnet number where the car is at

| **Basic** **Intermediate** **Advanced** **Administrator** | keypad **PC** **M2CS** | **Controller** **Car** | **Hydraulic** **Traction** |

01.09.05 - Magnet zone identifier

Shows the magnet zone where the car is at

| **Basic** **Intermediate** **Advanced** **Administrator** | keypad **PC** **M2CS** | **Controller** **Car** | **Hydraulic** **Traction** |

01.12 - SPS monitor

SPS information monitoring

| **Basic** Intermediate Advanced Administrator | keypad PC M2CS | Controller Car | Hydraulic Traction |

01.12.01 - Level

Shows the car level (in millimetres)

| **Basic** Intermediate Advanced Administrator | keypad PC M2CS | Controller Car | Hydraulic Traction |

01.12.02 - SPS programmed

Shows if the SPS is programmed

| **Basic** Intermediate Advanced Administrator | keypad PC M2CS | Controller Car | Hydraulic Traction |

01.12.03 - SPS consistent

Shows if the SPS is consistent

| **Basic** Intermediate Advanced Administrator | keypad PC M2CS | Controller Car | Hydraulic Traction |

01.12.04 - SPS and encoder communication established

Shows if the SPS and the encoder are communicating

| **Basic** Intermediate Advanced Administrator | keypad PC M2CS | Controller Car | Hydraulic Traction |

01.12.10 - SPS lift speed

Shows the speed readed by the SPS

| **Basic** Intermediate Advanced Administrator | keypad PC M2CS | Controller Car | Hydraulic Traction |

01.12.20 - SPS offset

Lets to know the correction made by the system at the encoder level

This parameter may be different from 0 and does not indicate a malfunction

| **Basic** Intermediate Advanced Administrator | keypad PC M2CS | Controller Car | Hydraulic Traction |

01.12.21 - SPS level of the last speed change

Lets to knows the last starting point of the slowing signal

| **Basic** Intermediate Advanced Administrator | keypad PC M2CS | Controller Car | Hydraulic Traction |

01.12.30 - SPS minimum braking distance

Shows the minimum distance required to stop the lift

This distance is measured during the SPS learning process

| **Basic** Intermediate Advanced Administrator | keypad PC M2CS | Controller Car | Hydraulic Traction |

01.12.75 - SPS firmware version

Shows the SPS firmware version

FACTORY DEFAULT: 0 0 0 0 0 0

| **Basic** Intermediate Advanced Administrator | keypad PC M2CS | Controller Car | Hydraulic Traction |

01.13 - SPS2 monitor

SPS information monitoring

| Basic Intermediate Advanced Administrator | keypad PC M2CS | Controller Car | Hydraulic Traction |

01.13.01 - Level

Shows the car level (in millimetres)

| Basic Intermediate Advanced Administrator | keypad PC M2CS | Controller Car | Hydraulic Traction |

01.13.02 - SPS programmed

Shows if the SPS is programmed

| Basic Intermediate Advanced Administrator | keypad PC M2CS | Controller Car | Hydraulic Traction |

01.13.04 - SPS and encoder communication established

Shows if the SPS and the encoder are communicating

| Basic Intermediate Advanced Administrator | keypad PC M2CS | Controller Car | Hydraulic Traction |

01.13.10 - SPS lift speed

Shows the speed readed by the SPS

| Basic Intermediate Advanced Administrator | keypad PC M2CS | Controller Car | Hydraulic Traction |

01.13.75 - SPS firmware version

Shows the SPS firmware version

| Basic Intermediate Advanced Administrator | keypad PC M2CS | Controller Car | Hydraulic Traction |

01.14 - Outputs monitor

| Basic Intermediate Advanced Administrator | keypad PC M2CS | Controller Car | Hydraulic Traction |

01.14.01 - Direction signals

| Basic Intermediate Advanced Administrator | keypad PC M2CS | Controller Car | Hydraulic Traction |

01.14.02 - Speed signals

| Basic Intermediate Advanced Administrator | keypad PC M2CS | Controller Car | Hydraulic Traction |

01.15 - Inputs monitor

Controller Inputs Monitoring

| Basic Intermediate Advanced Administrator | keypad PC M2CS | Controller Car | Hydraulic Traction |

01.15.01 - Series monitor

Controller series monitoring

| Basic Intermediate Advanced Administrator | keypad PC M2CS | Controller Car | Hydraulic Traction |

01.15.02 - Position monitor

Controller position monitoring

| Basic Intermediate Advanced Administrator | keypad PC M2CS | Controller Car | Hydraulic Traction |

01.15.03 - Brake contacts monitor

Controller brake contacts monitoring

| Basic Intermediate Advanced Administrator | keypad PC M2CS | Controller Car | Hydraulic Traction |

01.15.04 - Speed governor blocking contact monitor

Controller speed governor blocking contact monitoring

| Basic Intermediate Advanced Administrator | keypad PC M2CS | Controller Car | Hydraulic Traction |

01.15.05 - CPE monitor

Controller speed governor blocking contact monitoring

| Basic Intermediate Advanced Administrator | keypad PC M2CS | Controller Car | Hydraulic Traction |

01.15.11 - Car disable monitor

Monitor of the inputs that disables the car

| Basic Intermediate Advanced Administrator | keypad PC M2CS | Controller Car | Hydraulic Traction |

01.15.11.01 - Car disable signals monitor

ON - Input active and car disabled

Left - Disable input 1

Right - Disable input 2

| Basic Intermediate Advanced Administrator | keypad PC M2CS | Controller Car | Hydraulic Traction |

01.15.17 - Automatic entering under inspection

Monitor of the inputs that makes the lift enters automatically under inspection

| Basic Intermediate Advanced Administrator | keypad PC M2CS | Controller Car | Hydraulic Traction |

01.15.17.01 - Shaft access detection signal

ON - Input active and the lift enters under inspection

| Basic Intermediate Advanced Administrator | keypad PC M2CS | Controller Car | Hydraulic Traction |

01.15.20 - VIP signal monitor

Shows the VIP signal

ON - VIP activated

OFF - Deactivated

| Basic Intermediate Advanced Administrator | keypad PC M2CS | Controller Car | Hydraulic Traction |

01.15.50 - Door control signals monitor

Doors control signals monitoring

| Basic Intermediate Advanced Administrator | keypad PC M2CS | Controller Car | Hydraulic Traction |

01.15.51 - Photocell monitor

Show the photocells status.

Left-Photocell (1); Right-Photocell (2)

ON – Intercepted

OFF – Not Intercepted

| Basic Intermediate Advanced Administrator | keypad PC M2CS | Controller Car | Hydraulic Traction |

01.15.52 – Monitor of door 1 & door 2 fully opened signals

ON - Door fully opened
Left - Door 1 fully opened
Right - Door 2 fully opened

| Basic Intermediate Advanced Administrator | keypad PC M2CS | Controller Car | Hydraulic Traction |

01.15.60 – Overload sensor monitor

Show the overload sensor status.
Left – Overload; Right – Full Charge
ON – Overloaded /Full charge
OFF – Not Overloaded /without full charge

| Basic Intermediate Advanced Administrator | keypad PC M2CS | Controller Car | Hydraulic Traction |

01.15.65 – Hydraulic drive signals

| Basic Intermediate Advanced Administrator | keypad PC M2CS | Controller Car | Hydraulic Traction |

01.15.73 – EN81-73 monitor

EN81-73 signals monitor

| Basic Intermediate Advanced Administrator | keypad PC M2CS | Controller Car | Hydraulic Traction |

01.15.73.01 - Monitor of main & alternative alarm signals

ON - Input activated
Left - Main alarm
Right - Alternative alarm

| Basic Intermediate Advanced Administrator | keypad PC M2CS | Controller Car | Hydraulic Traction |

01.50 - Counters monitor

Allows monitoring the status of the different counters of the controller

| Basic Intermediate Advanced Administrator | keypad PC M2CS | Controller Car | Hydraulic Traction |

01.50.01 – Car calls for door 1

Monitors car calls for door 1

| Basic Intermediate Advanced Administrator | keypad PC M2CS | Controller Car | Hydraulic Traction |

01.50.02 – Car calls for door 2

Monitors car calls for door 2

| Basic Intermediate Advanced Administrator | keypad PC M2CS | Controller Car | Hydraulic Traction |

01.50.03 – Upward calls for door 1

Monitors upward calls for door 1

| Basic Intermediate Advanced Administrator | keypad PC M2CS | Controller Car | Hydraulic Traction |

01.50.04 – Upward calls for door 2

Monitors upward calls for door 2

| Basic Intermediate Advanced Administrator | keypad PC M2CS | Controller Car | Hydraulic Traction |

01.50.05 – Downward calls for door 1

Monitors downward calls for door 1

| Basic Intermediate Advanced Administrator | keypad PC M2CS | Controller Car | Hydraulic Traction |

01.50.06 – Downward calls for door 2

Monitors downward calls for door 2

| Basic Intermediate Advanced Administrator | keypad PC M2CS | Controller Car | Hydraulic Traction |

01.50.07 – Automatic calls

Monitors automatic calls of the controller

| Basic Intermediate Advanced Administrator | keypad PC M2CS | Controller Car | Hydraulic Traction |

01.50.50 - Trip counter

Total number of trips made by the lift

| Basic Intermediate Advanced Administrator | keypad PC M2CS | Controller Car | Hydraulic Traction |

01.50.51 - Minutes of operation

It shows minutes elapsed since last time controller was powered on

| Basic Intermediate Advanced Administrator | keypad PC M2CS | Controller Car | Hydraulic Traction |

01.50.52 - Total amount of working hours

Indicates the total amount of working hours of the Main CPU

| Basic Intermediate Advanced Administrator | keypad PC M2CS | Controller Car | Hydraulic Traction |

01.50.70 - CANC errors (%)

| Basic Intermediate Advanced Administrator | keypad PC M2CS | Controller Car | Hydraulic Traction |

01.60 - Events log

Log of the relevant events of the lift

| Basic Intermediate Advanced Administrator | keypad PC M2CS | Controller Car | Hydraulic Traction |

01.60.01 - 01.60.32 From Event number 1 to Event number 32

From Event stored onto register 1 to Event stored onto register 32

| Basic Intermediate Advanced Administrator | keypad PC M2CS | Controller Car | Hydraulic Traction |

01.70 - Hardware monitor

Allows to show the status of different elements of the system

| Basic Intermediate Advanced Administrator | keypad PC M2CS | Controller Car | Hydraulic Traction |

01.70.01 - Controller interface communication bus

OK - The controller is able to communicate with the power interface

| Basic Intermediate Advanced Administrator | keypad PC M2CS | Controller Car | Hydraulic Traction |

01.70.10 - Shaft CAN

Always OK - The shaft communication is working fine

Always ERROR - There is no communication with the shaft modules

Some ERROR - There is one or more landing modules without communication

| **Basic** **Intermediate** **Advanced** **Administrator** | keypad PC M2CS | Controller Car | Hydraulic Traction |

01.70.20 - Car CAN

OK - The communication with the car CPU is working fine

| **Basic** **Intermediate** **Advanced** **Administrator** | keypad PC M2CS | Controller Car | Hydraulic Traction |

01.70.30 - COP1 communication bus

OK - The communication with the COP1 board is working fine

ERROR - There is no communication with the COP1 board (maybe because there is nothing connected to its slot, the communication with the car CPU is missing or hardware error)

| **Basic** **Intermediate** **Advanced** **Administrator** | keypad PC M2CS | Controller Car | Hydraulic Traction |

01.70.31 - COP2 communication bus

OK - The communication with the COP2 board is working fine

ERROR - There is no communication with the COP2 board (maybe because there is nothing connected to its slot, The communication with the car CPU is missing or hardware error)

| **Basic** **Intermediate** **Advanced** **Administrator** | keypad PC M2CS | Controller Car | Hydraulic Traction |

01.70.40 - SAR communication bus

OK - the communication with the SAR is right

ERROR - There is no communication with the SAR (maybe because there is no SAR, The communication with the car CPU is missing or hardware error)

| **Basic** **Intermediate** **Advanced** **Administrator** | keypad PC M2CS | Controller Car | Hydraulic Traction |

01.70.90 - Micro SD

OK - The microSD is working fine

ERROR - there is no access to the microSD (maybe is not inserted, a wrong format or not compatible)

| **Basic** **Intermediate** **Advanced** **Administrator** | keypad PC M2CS | Controller Car | Hydraulic Traction |

02 - Configuration

Sets the specific parameters of the lift

02.01 - Main Parameters

Main parameters of the installation

02.01.02 - Top floor

Set this parameter at number of floor minus one

EXAMPLE: Set to 7 if the installation is 8 floors high

FACTORY DEFAULT: 1

MIN: 1

MAX: 31

STEP: 1

| **Basic** Intermediate Advanced Administrator | keypad PC M2CS | Controller Car | Hydraulic Traction |

02.01.03 – Main access floor stoppage time

Allows to define different stoppage time between main access floor and the others.

NOTE: The main access floor can be defined on parameter 02.04.02.02

FACTORY DEFAULT: 7 s

| **Basic** Intermediate Advanced Administrator | keypad PC M2CS | Controller Car | Hydraulic Traction |

02.01.04 – Floor Stoppage time

Sets the time the car is stopped on a floor, before closing doors and answering other calls.

FACTORY DEFAULT: 7 s

| **Basic** Intermediate Advanced Administrator | keypad PC M2CS | Controller Car | Hydraulic Traction |

02.01.06 - Assembly period mode

This parameter is used during assembly period only. In assembly mode it is able to move in inspection mode (When not under inspection mode it's out of service)

0 - Assembly mode period disabled (Normal operation of the lift, once completely installed)

1 - Assembly mode period enabled (Car moves in inspection mode only)

FACTORY DEFAULT: 1

| **Basic** Intermediate Advanced Administrator | keypad PC M2CS | Controller Car | Hydraulic Traction |

02.01.07 - Under inspection stops on CV signals

Car travel, under inspection, to limit floor or only to the CV signal

0 - Under inspection, stops on limit floor

1 - Under inspection, stops on CV signals

NOTE: If this parameter is set to 0 (stops on limit floor under inspection) the car will stop on CV signal. Then is necessary to release the inspection push buttons and press again in order to start again the car, at low speed between, CV signals and limit floor level

FACTORY DEFAULT: 1

| **Basic** Intermediate Advanced Administrator | keypad PC M2CS | Controller Car | Hydraulic Traction |

02.01.08 - Positioning mode

Sets the positioning mode of the lift.

2P - 2 magnets between floors

MAN - Manual table (only necessary on installations with special configuration)

SPS - Shaft positioning system (Encoder based positioning)

FACTORY DEFAULT: 2P

| **Basic** Intermediate Advanced Administrator | keypad PC M2CS | Controller Car | Hydraulic Traction |

02.01.09 - SPS model

In case of SPS positioning system, this parameter sets the SPS model.

| **Basic** Intermediate Advanced Administrator | keypad PC M2CS | Controller Car | Hydraulic Traction |

02.01.10 - Non collective operation

Sets the collection type of the elevator

0 - Collective

1 - No collective (One landing call at a time)

FACTORY DEFAULT: 0

| **Basic** Intermediate Advanced Administrator | keypad PC M2CS | Controller Car | Hydraulic Traction |

02.02 - Doors

Door configuration parameters

02.02.01 - Doors global parameters

Sets the doors parameters relating to general settings of all the floors

| **Basic** Intermediate Advanced Administrator | keypad PC M2CS | Controller Car | Hydraulic Traction |

02.02.01.01 - CAM

Sets if Hidra Crono needs CAM control or not

0 - CAM control not needed

1 - CAM control needed

FACTORY DEFAULT: 0

| **Basic** Intermediate Advanced Administrator | keypad PC M2CS | Controller Car | Hydraulic Traction |

02.02.01.02 - Door close time limit

Sets the maximum time allowed for door close command. When this time expires, the control panel reopens door and will give door close command afterwards.

FACTORY DEFAULT: 7 s

| **Basic** Intermediate Advanced Administrator | keypad PC M2CS | Controller Car | Hydraulic Traction |

02.02.01.03 - Close door attempts

Sets the number of close door attempts before enter in blocked door mode

FACTORY DEFAULT: 10

MIN: 10

MAX: 20

STEP: 1

| **Basic** Intermediate Advanced Administrator | keypad PC M2CS | Controller Car | Hydraulic Traction |

02.02.01.04 - Blocked door timer

Sets the maximum time allowed for Photocell interception or DOP press before entering blocked door mode

FACTORY DEFAULT: 30 s

| **Basic** Intermediate Advanced Administrator | keypad PC M2CS | Controller Car | Hydraulic Traction |

02.02.01.05 - Time to quit blocked door mode

If the maximum number of closing door attempts is reached, the Hidra Crono enters in blocked door mode during the time set on this parameter

Set this time high enough to prevent the door operator failure by an excessive number of attempts due to a series error

FACTORY DEFAULT: 5 min

| **Basic** **Intermediate** **Advanced** **Administrator** | keypad PC M2CS | Controller Car | Hydraulic Traction |

02.02.01.06 - Reopening due to a landing call

If the car is closing the door and a new landing call appears this parameter allows the re-opening the door or not

0 - Reopening is not allowed with a landing call

1 - Reopening is allowed with a landing call

NOTE: Even if this parameter is set to 1 (Reopening allowed) the car is going to reopen only if the landing call is in the same direction of the car

FACTORY DEFAULT: 1

| **Basic** **Intermediate** **Advanced** **Administrator** | keypad PC M2CS | Controller Car | Hydraulic Traction |

02.02.01.07 - Photocell attempts

Sets the maximum number of photocell interceptions allowed before entering door block mode.

FACTORY DEFAULT: 10

MIN: 3

MAX: 20

STEP: 1

| **Basic** **Intermediate** **Advanced** **Administrator** | keypad PC M2CS | Controller Car | Hydraulic Traction |

02.02.01.08 - Time to set doors on rest mode

Set the time before doors reach its rest mode.

NOTE: The door rest mode could be different each floor

FACTORY DEFAULT: 30 s

| **Basic** **Intermediate** **Advanced** **Administrator** | keypad PC M2CS | Controller Car | Hydraulic Traction |

02.02.01.09 - Maximum time allowed, while running, with door series open

When the car is moving and the doors series opens, it will stop immediately, and will wait the time set in this parameter, for the door series to close again, in order to continue the travel. If the time set on this parameter expires, its status changes to out of service

NOTE: Set this parameter to 0 s to become out of service immediately

FACTORY DEFAULT: 10 s

| **Basic** **Intermediate** **Advanced** **Administrator** | keypad PC M2CS | Controller Car | Hydraulic Traction |

02.02.01.10 - Doors speech synthesis

Enables or disables 'door opening' and 'door closing' speech synthesis

0 - Disables

1 - Enabled

FACTORY DEFAULT: 1

| **Basic** **Intermediate** **Advanced** **Administrator** | keypad PC M2CS | Controller Car | Hydraulic Traction |

02.02.01.30 - Out for the retiring ramp

Definition of the output where the retiring ramp is connected to

FACTORY DEFAULT: No USE

| **Basic** **Intermediate** **Advanced** **Administrator** | keypad PC M2CS | Controller Car | Hydraulic Traction |

02.02.02 - Floor dependent door parameters

Adjust the parameters relating to the door on each floor

| **Basic** **Intermediate** **Advanced** **Administrator** | keypad PC M2CS | Controller Car | Hydraulic Traction |

02.02.02.01 - 02.02.02.32 From Floor 0 door configuration to Floor 31 door configuration

A - Door 1 operator enabled (UNCHECKED - Disabled)

B - Door 2 operator enabled (UNCHECKED - Disabled)

C - Door 1 open in rest state (UNCHECKED closed at rest state)

D - Door 2 open in rest state (UNCHECKED closed at rest state)

E - Selective entrance (UNCHECKED double entrance)

F - Allows to open both doors together (UNCHECKED prevents both doors from being opened simultaneously)

G – Not defined

H – Not defined

FACTORY DEFAULT: A - 1 / B - 0 / C - 0 / D - 0 / E - 0 / F - 0 / G - 0 / H - 0

NOTE: 0 - FALSE / 1 – TRUE

| **Basic** **Intermediate** **Advanced** **Administrator** | keypad PC M2CS | Controller Car | Hydraulic Traction |

02.02.03 - Advanced door opening

Set the parameters of the advanced door opening function

| **Basic** **Intermediate** **Advanced** **Administrator** | keypad PC M2CS | Controller Car | Hydraulic Traction |

02.02.03.01 - Advanced door opening enable

Allows enabling or disabling the advanced door opening

0 - Not advanced (Door opens on machine stop)

1 - Advanced (Door opens on floor arrival)

NOTE: In order to open the door while the car is still moving is necessary to have a safety circuit (CSG) on control panel to allow the series link only at unlocking zone

FACTORY DEFAULT: 0

| **Basic** **Intermediate** **Advanced** **Administrator** | keypad PC M2CS | Controller Car | Hydraulic Traction |

02.02.03.02 - Point of advanced door opening

In case of advanced door opening enabled, this parameter sets the point to open it

0 - When CDI or CDP is detected (no overlap)

1 - When CDI and CDP is detected (CDI and CDP overlap)

FACTORY DEFAULT: 0

| **Basic** **Intermediate** **Advanced** **Administrator** | keypad PC M2CS | Controller Car | Hydraulic Traction |

02.02.05 - Behavior in case of photocell block

If the door is going to close, but the photocell is blocked too much time, this parameter sets the behavior of the lift

0 - The door will remain open, and the lift out of service until the photocell is cleared

1 - The door will be closed ignoring the photocell. It will be closed at reduced power and at the same time an acoustic warning will sound on the COP

| **Basic** **Intermediate** **Advanced** **Administrator** | keypad PC M2CS | Controller Car | Hydraulic Traction |

02.02.50 - Inputs and outputs of door operators

| **Basic** **Intermediate** **Advanced** **Administrator** | keypad PC M2CS | Controller Car | Hydraulic Traction |

02.02.50.01 - Output signal for close door 1 under reduced power

Defines where is located the output signal for close door 1 under reduced power

| Basic Intermediate Advanced Administrator | keypad PC M2CS | Controller Car | Hydraulic Traction |

02.02.50.02 - Output signal for close door 2 under reduced power

Defines where is located the output signal for close door 2 under reduced power

| Basic Intermediate Advanced Administrator | keypad PC M2CS | Controller Car | Hydraulic Traction |

02.02.50.10 - Input for the door closed signal

This input indicates to the controller that the doors are closed

This is an additional input. IS NOT THE CHAIN

ATTENTION: NEVER CONNECT THIS INPUT IN PARALLEL WITH THE CHAIN or the controller will be damaged

| Basic Intermediate Advanced Administrator | keypad PC M2CS | Controller Car | Hydraulic Traction |

02.02.50.20 - Input for the signal of door operator temperature

This input indicates to the controller that the door operators are working inside its temperature range

The controller needs an open contact inside temperature range that must close on over temperature

| Basic Intermediate Advanced Administrator | keypad PC M2CS | Controller Car | Hydraulic Traction |

02.03 - Indications

Sets the user indication parameters

02.03.01 - Direction arrows

Set the behaviour of the arrows indicators

0 - Next direction arrows lights up only on the floor the car is at

1 - Direction arrows lights up on every floor and next direction arrow lights up on the floor the car is at

FACTORY DEFAULT: 0

| Basic Intermediate Advanced Administrator | keypad PC M2CS | Controller Car | Hydraulic Traction |

02.03.02 - Display

Setting of the display symbols shown on each floor

Symbol table of the standard display

-3 , -2 , -1 , 0 , 1 , 2 , 3 , 4 , 5 , 6 , 7 , 8 , 9 , 10 , 11 , 12 , 13 , 14 , 15 , 16 , 17 , 18 , 19 , 20 , 21 , 22 , 23 , 24 , 1A , 1B , 2A , 2B , 3A , 3B , A , B , BAR , C , CAR , E , G , G1 , G2 , G3 , H , L , LB , LG , M , P , PB , PH , PR , R , RC , RI , RJ , RS , S , S1 , S2 , S3 , SA , SS , T , U , UG , Z

NOTE: Symbols not included in this table require a sequential display

| Basic Intermediate Advanced Administrator | keypad PC M2CS | Controller Car | Hydraulic Traction |

02.03.02.01 - 02.03.02.32 From Floor 0 display symbol to Floor 31 display symbol

Programming of the symbol to display when the car is in this floor

FACTORY DEFAULT Floor 0	0
FACTORY DEFAULT Floor 1	1
FACTORY DEFAULT Floor 2	2
FACTORY DEFAULT Floor 3	3
FACTORY DEFAULT Floor 4	4
FACTORY DEFAULT Floor 5	5
FACTORY DEFAULT Floor 6	6
FACTORY DEFAULT Floor 7	7
FACTORY DEFAULT Floor 8	8
FACTORY DEFAULT Floor 9	9
FACTORY DEFAULT Floor 10	10

FACTORY DEFAULT Floor 11	11
FACTORY DEFAULT Floor 12	12
FACTORY DEFAULT Floor 13	13
FACTORY DEFAULT Floor 14	14
FACTORY DEFAULT Floor 15	15
FACTORY DEFAULT Floor 16	16
FACTORY DEFAULT Floor 17	17
FACTORY DEFAULT Floor 18	18
FACTORY DEFAULT Floor 19	19
FACTORY DEFAULT Floor 20	20
FACTORY DEFAULT Floor 21	21
FACTORY DEFAULT Floor 22	22
FACTORY DEFAULT Floor 23	23
FACTORY DEFAULT Floor 24	24
FACTORY DEFAULT Floor 25	1
FACTORY DEFAULT Floor 26	1
FACTORY DEFAULT Floor 27	1
FACTORY DEFAULT Floor 28	1
FACTORY DEFAULT Floor 29	1
FACTORY DEFAULT Floor 30	1
FACTORY DEFAULT Floor 31	1

| Basic Intermediate Advanced Administrator | keypad PC M2CS | Controller Car | Hydraulic Traction |

02.03.03 - Acoustic

Setting of the speech synthesis to be heard on each floor

Synthesis table

	SYNTHESIS
M1	FIRST FLOOR
M2	SECOND FLOOR
M3	THIRD FLOOR
M4	FOURTH FLOOR
M5	FIFTH FLOOR
M6	SIXTH FLOOR
M7	SEVENTH FLOOR
M8	EIGHTH FLOOR
M9	NINTH FLOOR
M10	TENTH FLOOR
M11	ELEVENTH FLOOR
M12	TWELFTH FLOOR
M13	THIRTEENTH FLOOR
M14	FOURTEENTH FLOOR
M15	<Not assigned>
M16	<Not assigned>
M17	<Not assigned>
M18	<Not assigned>
M19	<Not assigned>
M20	<Not assigned>
M21	<Not assigned>
M22	<Not assigned>
M23	<Not assigned>
M24	<Not assigned>
M25	<Not assigned>
M26	<Not assigned>
M27	<Not assigned>
M28	<Not assigned>
M29	<Not assigned>
M30	<Not assigned>

M31	BASEMENT
M32	FLOOR MINUS ONE
M33	FLOOR MINUS TWO
M34	FLOOR MINUS THREE
M35	<Not assigned>
M36	<Not assigned>
M37	PENTHOUSE
M38	<Not assigned>
M39	<Not assigned>
M40	<Not assigned>
M41	<Not assigned>
M42	MEZZANINE
M43	<Not assigned>
M44	<Not assigned>
M45	<Not assigned>
M46	<Not assigned>
M47	<Not assigned>
M48	<Not assigned>
M49	<Not assigned>
M50	ATTIC
M51	<Not assigned>
M52	<Not assigned>
M53	<Not assigned>
M54	<Not assigned>
M55	<Not assigned>
M56	<Not assigned>
M57	FLOOR ZERO
M58	CAR PARK
M59	RESTAURANT
M60	LOBBY
M61	LOWER GROUND FLOOR
M62	UPPER GROUND FLOOR
M63	<Not assigned>
M64	<Not assigned>
M65	GROUND FLOOR
M66	<Not assigned>
M67	RESTAURANT
M68	<Not assigned>

NOTE: Messages not included in this table require a special voice synthesizer

| **Basic Intermediate Advanced Administrator** | keypad PC M2CS | **Controller Car** | **Hydraulic Traction** |

02.03.03.01 - 02.03.03.32 From Floor 0 speech synthesis to Floor 31 speech synthesis

Programming of the speech synthesis to be heard when car is on this floor

FACTORY DEFAULT Floor 0	M57
FACTORY DEFAULT Floor 1	M1
FACTORY DEFAULT Floor 2	M2
FACTORY DEFAULT Floor 3	M3
FACTORY DEFAULT Floor 4	M4
FACTORY DEFAULT Floor 5	M5
FACTORY DEFAULT Floor 6	M6
FACTORY DEFAULT Floor 7	M7
FACTORY DEFAULT Floor 8	M8
FACTORY DEFAULT Floor 9	M9
FACTORY DEFAULT Floor 10	M10

FACTORY DEFAULT Floor 11	M11
FACTORY DEFAULT Floor 12	M12
FACTORY DEFAULT Floor 13	M13
FACTORY DEFAULT Floor 14	M14
FACTORY DEFAULT Floor 15	M1
FACTORY DEFAULT Floor 16	M1
FACTORY DEFAULT Floor 17	M1
FACTORY DEFAULT Floor 18	M1
FACTORY DEFAULT Floor 19	M1
FACTORY DEFAULT Floor 20	M1
FACTORY DEFAULT Floor 21	M1
FACTORY DEFAULT Floor 22	M1
FACTORY DEFAULT Floor 23	M1
FACTORY DEFAULT Floor 24	M1
FACTORY DEFAULT Floor 25	M1
FACTORY DEFAULT Floor 26	M1
FACTORY DEFAULT Floor 27	M1
FACTORY DEFAULT Floor 28	M1
FACTORY DEFAULT Floor 29	M1
FACTORY DEFAULT Floor 30	M1
FACTORY DEFAULT Floor 31	M1

| Basic Intermediate Advanced Administrator | keypad PC M2CS | Controller Car | Hydraulic Traction |

02.03.04 - Car here light

Light indicator of car here

| Basic Intermediate Advanced Administrator | keypad PC M2CS | Controller Car | Hydraulic Traction |

02.03.04.01 - Car here light enable

Enables or disable the car here light function

0 - Car here light disabled

1 - Car here light enabled

FACTORY DEFAULT: 0

| Basic Intermediate Advanced Administrator | keypad PC M2CS | Controller Car | Hydraulic Traction |

02.03.04.02 - 02.03.04.33 From Car here light for floor 0 to Car here light for floor 31

Defines where car here light is connected for each floor

FACTORY DEFAULT Floor 0	L0012
FACTORY DEFAULT Floor 1	L0112
FACTORY DEFAULT Floor 2	L0212
FACTORY DEFAULT Floor 3	L0312
FACTORY DEFAULT Floor 4	L0412
FACTORY DEFAULT Floor 5	L0512
FACTORY DEFAULT Floor 6	L0612
FACTORY DEFAULT Floor 7	L0712
FACTORY DEFAULT Floor 8	L0812
FACTORY DEFAULT Floor 9	L0912
FACTORY DEFAULT Floor 10	L1012
FACTORY DEFAULT Floor 11	L1112
FACTORY DEFAULT Floor 12	L1212
FACTORY DEFAULT Floor 13	L1312
FACTORY DEFAULT Floor 14	L1412
FACTORY DEFAULT Floor 15	L1512
FACTORY DEFAULT Floor 16	L1612
FACTORY DEFAULT Floor 17	L1712
FACTORY DEFAULT Floor 18	L1812
FACTORY DEFAULT Floor 19	L1912
FACTORY DEFAULT Floor 20	L2012
FACTORY DEFAULT Floor 21	L2112
FACTORY DEFAULT Floor 22	L2212

FACTORY DEFAULT Floor 23	L2312
FACTORY DEFAULT Floor 24	L2412
FACTORY DEFAULT Floor 25	L2512
FACTORY DEFAULT Floor 26	L2612
FACTORY DEFAULT Floor 27	L2712
FACTORY DEFAULT Floor 28	L2812
FACTORY DEFAULT Floor 29	L2912
FACTORY DEFAULT Floor 30	L3012
FACTORY DEFAULT Floor 31	L3112

| **Basic** **Intermediate** **Advanced** **Administrator** | keypad PC M2CS | Controller Car | Hydraulic Traction |

02.03.05 - Show double symbols on displays

In some special cases, as if the lift is under VIP function, the displays will show double symbol with the floor info and the special info

0 - The displays will not show double symbols

1 - The displays will show double symbols on special cases

NOTE: This function is not compatible with old displays as DMR and in those special cases the displays will show a strange symbol. If this is the case, set this parameter to 0

| **Basic** **Intermediate** **Advanced** **Administrator** | keypad PC M2CS | Controller Car | Hydraulic Traction |

02.03.07 - Car GONG mode of operation

Sets the car GONG mode of operation

0 - Indicates next direction

1 - Indicates car arrival

FACTORY DEFAULT: 0

| **Basic** **Intermediate** **Advanced** **Administrator** | keypad PC M2CS | Controller Car | Hydraulic Traction |

02.03.10 - LCD text

Allow customization of LCD text to be shown on the handheld console

| **Basic** **Intermediate** **Advanced** **Administrator** | keypad PC M2CS | Controller Car | Hydraulic Traction |

02.03.20 - Acoustic indication of door opened

Allows to indicate with an acoustic indication in the COP if the manual door is opened too much time

This acoustic indication remains until the door closes or enters on the blocked door state

0 - Disable acoustic indication

1 - Enable acoustic indication

| **Basic** **Intermediate** **Advanced** **Administrator** | keypad PC M2CS | Controller Car | Hydraulic Traction |

02.03.25 - Auxiliary output for overload indication

Defines an output to indicate overload

| **Basic** **Intermediate** **Advanced** **Administrator** | keypad PC M2CS | Controller Car | Hydraulic Traction |

02.03.30 - Car light lit indication

FACTORY DEFAULT: NOUSE

| **Basic** **Intermediate** **Advanced** **Administrator** | keypad PC M2CS | Controller Car | Hydraulic Traction |

02.03.40 - Fire alarm indication

FACTORY DEFAULT: NOUSE

| **Basic** **Intermediate** **Advanced** **Administrator** | keypad PC M2CS | Controller Car | Hydraulic Traction |

02.03.80 – Under public service indication

| Basic Intermediate Advanced Administrator | keypad PC M2CS | Controller Car | Hydraulic Traction |

02.03.81 – Out of service indication

| Basic Intermediate Advanced Administrator | keypad PC M2CS | Controller Car | Hydraulic Traction |

02.03.82 – Under inspection indication

| Basic Intermediate Advanced Administrator | keypad PC M2CS | Controller Car | Hydraulic Traction |

02.03.85 – Idle indication

| Basic Intermediate Advanced Administrator | keypad PC M2CS | Controller Car | Hydraulic Traction |

02.03.86 – Lift going up indication

| Basic Intermediate Advanced Administrator | keypad PC M2CS | Controller Car | Hydraulic Traction |

02.03.87 – Lift going down indication

| Basic Intermediate Advanced Administrator | keypad PC M2CS | Controller Car | Hydraulic Traction |

02.03.88 – Trip indication

FACTORY DEFAULT: NOUSE

| Basic Intermediate Advanced Administrator | keypad PC M2CS | Controller Car | Hydraulic Traction |

02.03.90 – Doors opened indication

| Basic Intermediate Advanced Administrator | keypad PC M2CS | Controller Car | Hydraulic Traction |

02.03.91 – Doors closed indication

| Basic Intermediate Advanced Administrator | keypad PC M2CS | Controller Car | Hydraulic Traction |

02.04 - Car homing and automatic calls

Setting of the parameters related with automatic functions and homing

02.04.01 - Homing

Set the parameters of the homing function

| Basic Intermediate Advanced Administrator | keypad PC M2CS | Controller Car | Hydraulic Traction |

02.04.01.01 - Return enable

Enables or disables automatic returns to homing floor

0 - Return disabled

1 - Return enabled

NOTE: If return is enabled (Parameter value is 1) the car returns to homing floor, when the timer set in return timer is reached.

FACTORY DEFAULT: 0

| Basic Intermediate Advanced Administrator | keypad PC M2CS | Controller Car | Hydraulic Traction |

02.04.01.02 - Homing floor

Sets the homing floor in case of automatic return enabled

FACTORY DEFAULT: 0

MIN: 0

MAX: 31

STEP: 1

| Basic Intermediate Advanced Administrator | keypad PC M2CS | Controller Car | Hydraulic Traction |

02.04.01.03 - Return timer

Sets the time the car is stopped, before returning to homing floor

NOTE: Adjust this parameter to 0 s to return when stop time finishes. FACTORY DEFAULT: 1 min

| Basic Intermediate Advanced Administrator | keypad PC M2CS | Controller Car | Hydraulic Traction |

02.04.02 - Basement return

Basement return setting

| Basic Intermediate Advanced Administrator | keypad PC M2CS | Controller Car | Hydraulic Traction |

02.04.02.01 - Basement return enable

Enables or disables automatic basement returns to homing floor

0 - Basement return disabled

1 - Basement return enabled

NOTE: Each floor below basement return floor is considered basement

FACTORY DEFAULT: 0

| Basic Intermediate Advanced Administrator | keypad PC M2CS | Controller Car | Hydraulic Traction |

02.04.02.02 - Basement return floor

Sets the floor to return from basement

FACTORY DEFAULT: 0

MIN: 0

MAX: 31

STEP: 1

| Basic Intermediate Advanced Administrator | keypad PC M2CS | Controller Car | Hydraulic Traction |

02.04.02.03 - Basement return timer

Sets the time to wait before car returns from basement to homing floor

NOTE: Adjust this parameter to 0 s to return when stop time finish

FACTORY DEFAULT: 1 min

| Basic Intermediate Advanced Administrator | keypad PC M2CS | Controller Car | Hydraulic Traction |

02.04.03 - Car Disable

Allows to leave the car without service.

| Basic Intermediate Advanced Administrator | keypad PC M2CS | Controller Car | Hydraulic Traction |

02.04.03.01 - Input signal for car disable 1

Input to leave the car parked on park floor 1.

FACTORY DEFAULT: NOUSE

| Basic Intermediate Advanced Administrator | keypad PC M2CS | Controller Car | Hydraulic Traction |

02.04.03.02 - Floor to park on disable 1 signal

Floor where the car parks when Input signal 1 is activated.

FACTORY DEFAULT: 0

| Basic Intermediate Advanced Administrator | keypad PC M2CS | Controller Car | Hydraulic Traction |

02.04.03.11 - Input signal for car disable 2

Input to leave the car parked on park floor 2.

FACTORY DEFAULT: NOUSE

| Basic Intermediate Advanced Administrator | keypad PC M2CS | Controller Car | Hydraulic Traction |

02.04.03.12 - Floor to park on disable 2 signal

Floor where the car parks when Input signal 2 is activated.

FACTORY DEFAULT: 1

| Basic Intermediate Advanced Administrator | keypad PC M2CS | Controller Car | Hydraulic Traction |

02.04.05 - Doors opening when automatic returns

Sets if the car is going to open doors upon automatic returns

0 - No doors opening

1 - With doors opening

NOTE: If this parameter is set to 1, the car is going to open the door assigned at homing floor. FACTORY DEFAULT: 0

| Basic Intermediate Advanced Administrator | keypad PC M2CS | Controller Car | Hydraulic Traction |

02.04.10 - Leveling

The lift will be leveled if due to a loading or unloading operation the car leaves the stop leveling zone.

| Basic Intermediate Advanced Administrator | keypad PC M2CS | Controller Car | Hydraulic Traction |

02.04.10.01 - Leveling enable

Leveling enable

0 – Disabled

1 – Enabled

NOTE: In order to level with open door, it's necessary to have a safety circuit (CSG) in the control panel to allow the series link only at unlocking zone. FACTORY DEFAULT: 0

| Basic Intermediate Advanced Administrator | keypad PC M2CS | Controller Car | Hydraulic Traction |

02.05 - Drive type parameters

Setting of the drive type dependant parameters

| Basic Intermediate Advanced Administrator | keypad PC M2CS | Controller Car | Hydraulic Traction |

02.05.10 - Control type

Sets the type of control

0 - Fuji drive

1 - Control techniques drive

2 - 2 speeds control

| Basic Intermediate Advanced Administrator | keypad PC M2CS | Controller Car | Hydraulic Traction |

02.05.11 - Demagnetizing time

Set the time required to demagnetize the machine (Only synchronous machines)

FACTORY DEFAULT: 0,75 s

| Basic Intermediate Advanced Administrator | keypad PC M2CS | Controller Car | Hydraulic Traction |

02.05.50 - Motor configuration

Sets the motor parameters

| [Basic](#) [Intermediate](#) [Advanced](#) [Administrator](#) | [keypad](#) [PC](#) [M2CS](#) | [Controller](#) [Car](#) | [Hydraulic](#) [Traction](#) |

02.05.50.01 - Selection of direct start or star-delta start

Sets the motor starting mode

0 - Star Delta start

1 - Direct start

| [Basic](#) [Intermediate](#) [Advanced](#) [Administrator](#) | [keypad](#) [PC](#) [M2CS](#) | [Controller](#) [Car](#) | [Hydraulic](#) [Traction](#) |

02.05.50.10 - Star time

Sets the star time

| [Basic](#) [Intermediate](#) [Advanced](#) [Administrator](#) | [keypad](#) [PC](#) [M2CS](#) | [Controller](#) [Car](#) | [Hydraulic](#) [Traction](#) |

02.05.50.20 - Time between star and delta

Sets the time between the star disconnection and the delta connection

| [Basic](#) [Intermediate](#) [Advanced](#) [Administrator](#) | [keypad](#) [PC](#) [M2CS](#) | [Controller](#) [Car](#) | [Hydraulic](#) [Traction](#) |

02.05.60 - Motor disconnection delay

Sets the time elapsed between the disconnection of the speed signals and motor stop (softstop)

| [Basic](#) [Intermediate](#) [Advanced](#) [Administrator](#) | [keypad](#) [PC](#) [M2CS](#) | [Controller](#) [Car](#) | [Hydraulic](#) [Traction](#) |

02.05.65 - Speed signals connection delay after motor

Sets the time elapsed between the connection of the motor and the connection of the speed signals on the hydraulic drive

| [Basic](#) [Intermediate](#) [Advanced](#) [Administrator](#) | [keypad](#) [PC](#) [M2CS](#) | [Controller](#) [Car](#) | [Hydraulic](#) [Traction](#) |

02.05.70 - Valve block

Sets the valve block type

10 - Non electronic valve block

20 – NGV-A3

30 – iVALVE

FACTORY DEFAULT: 20

| [Basic](#) [Intermediate](#) [Advanced](#) [Administrator](#) | [keypad](#) [PC](#) [M2CS](#) | [Controller](#) [Car](#) | [Hydraulic](#) [Traction](#) |

02.05.80 - Safety valve test

When necessary, allows an automatic and periodic test of leakage of the safety valve (also known as pilot valve or UCM valve)

| [Basic](#) [Intermediate](#) [Advanced](#) [Administrator](#) | [keypad](#) [PC](#) [M2CS](#) | [Controller](#) [Car](#) | [Hydraulic](#) [Traction](#) |

02.08.80.01 - Safety valve test enable

0 - Automatic test disabled

1 - automatic test enabled

| [Basic](#) [Intermediate](#) [Advanced](#) [Administrator](#) | [keypad](#) [PC](#) [M2CS](#) | [Controller](#) [Car](#) | [Hydraulic](#) [Traction](#) |

02.08.80.05 - Do the safety valve test just now

Performs the safety valve test without waiting for the set time

| Basic Intermediate Advanced Administrator | keypad PC M2CS | Controller Car | Hydraulic Traction |

02.08.80.10 - Time between safety valve tests

Sets the time between automatic tests

NOTE: When necessary, set to the time recommended by the safety valve manufacturer

| Basic Intermediate Advanced Administrator | keypad PC M2CS | Controller Car | Hydraulic Traction |

02.08.80.20 - Valve opening time

Sets the time that the valve remains open during the automatic test

| Basic Intermediate Advanced Administrator | keypad PC M2CS | Controller Car | Hydraulic Traction |

02.06 - Low Consumption (Energy Efficiency)

Setting of the parameters related to low consumption (energy efficiency)

02.06.01 - Car light

Set of the parameters that allows to reduce energy consumption with the car light

| Basic Intermediate Advanced Administrator | keypad PC M2CS | Controller Car | Hydraulic Traction |

02.06.01.01 - Car light timer

Time until car lights are turned off once the doors reach rest state

NOTE: Set to NO for car light always light, 0 s for light off immediately after doors reach rest state or the desired time

FACTORY DEFAULT: 5 min

| Basic Intermediate Advanced Administrator | keypad PC M2CS | Controller Car | Hydraulic Traction |

02.06.01.02 - Turn off car light only with door closed

Manages the switch off of the car light, depending on door position

0 - Car light always switches off

1 - Car light switches off when doors are closed

FACTORY DEFAULT: 1

| Basic Intermediate Advanced Administrator | keypad PC M2CS | Controller Car | Hydraulic Traction |

02.06.02 - Call acceptance light brightness

Allows to change the call acceptance light brightness between 100%, 75%, 50% and 25% of the total brightness

FACTORY DEFAULT: 100%

| Basic Intermediate Advanced Administrator | keypad PC M2CS | Controller Car | Hydraulic Traction |

02.06.03 - Time to set displays to a low consumption mode

Delay to set the displays to a low consumption mode once the doors reach rest state

NOTE: Set to NO to disable this feature, 0 s to enter low consumption mode immediately after doors reach rest state or, then, the desired time. FACTORY DEFAULT: NO

| Basic Intermediate Advanced Administrator | keypad PC M2CS | Controller Car | Hydraulic Traction |

02.07 - Rescues

Parameter setting related to automatic rescues

02.07.10 - Rescue mode

Adjust the rescue mode

0 - Without automatic rescue

1 – Automatic, by unbalance

2 – Automatic, at low speed, to most favourable floor

3 – Automatic, at low speed, to the extreme floor

4 – Automatic, at low speed, to a pre-determined floor

NOTE: Rescue modes 2, 3 and 4 are not available on all combinations of type of installation/inverter/power consumption. Please contact our services. FACTORY DEFAULT: 0

| Basic Intermediate Advanced Administrator | keypad PC M2CS | Controller Car | Hydraulic Traction |

02.07.20 – Automatic, unbalanced rescue

With this rescue, in the event of a power failure, the controller safely moves the lift to the nearest, most favourable, floor. Once the floor is reached, doors will open to allow evacuation. This movement is made by unbalance so the rescue floor can't be set

NOTE: this function requires, an optional device to enable the automatic rescue by unbalance, definition of the control output in this menu

| Basic Intermediate Advanced Administrator | keypad PC M2CS | Controller Car | Hydraulic Traction |

02.07.20.01 - Signal to allow the automatic rescue by unbalance

Output signal to enable automatic rescue by unbalance

FACTORY DEFAULT: Not assigned

| Basic Intermediate Advanced Administrator | keypad PC M2CS | Controller Car | Hydraulic Traction |

02.07.30 – Automatic, at low speed, to most favourable floor

In case of power failure, with car outside floor zone, the controller will move the car, at low speed, in the most favourable direction. When floor level is reached, the controller stops and opens both doors sequentially

NOTE: This rescue is not available on all combinations of power consumption/inverter/type of installation, please contact customer

| Basic Intermediate Advanced Administrator | keypad PC M2CS | Controller Car | Hydraulic Traction |

02.07.30.01 - When the lift is going up the inverter indicates

It is necessary to correctly adjust this parameter, otherwise, during a rescue a current overload UPS error could happen

FWD – Going up the inverter indicates forward (FWD)

REV – Going up the inverter indicates reverse (REV)

FACTORY DEFAULT: FWD

| Basic Intermediate Advanced Administrator | keypad PC M2CS | Controller Car | Hydraulic Traction |

02.07.35 – Automatic rescue to a extreme floor

| Basic Intermediate Advanced Administrator | keypad PC M2CS | Controller Car | Hydraulic Traction |

02.07.35.01 - Rescue to a bottom or top floor

Allows to select if the rescue is done to the bottom or to the top floor

DW - It will be done to the bottom floor

UP - It will be done to the top floor

FACTORY DEFAULT: DW

| Basic Intermediate Advanced Administrator | keypad PC M2CS | Controller Car | Hydraulic Traction |

02.07.40 - Defined floor rescue

Floor to rescue in necessary case

| Basic Intermediate Advanced Administrator | keypad PC M2CS | Controller Car | Hydraulic Traction |

02.07.40.01 - Rescue floor

Floor to rescue in necessary case

| Basic Intermediate Advanced Administrator | keypad PC M2CS | Controller Car | Hydraulic Traction |

02.07.40.02 - Always rescue to the defined floor

If the controller is powered by an UPS, a rescue operation will be started always or only if the car is out of the unlocking zone

0 - If the car is at unlocking zone, the doors will be opened. If the car is out of unlocking zone, a rescue to the defined floor will be started

1 - The car will start a rescue operation always to the defined floor

| Basic Intermediate Advanced Administrator | keypad PC M2CS | Controller Car | Hydraulic Traction |

02.07.45 - Hydraulic rescue

Sets the parameters related with the hydraulic rescue

| Basic Intermediate Advanced Administrator | keypad PC M2CS | Controller Car | Hydraulic Traction |

02.07.45.01 - Rescue to the lowest floor

Adjust where the rescue is made

0 - To the nearest floor down

1 - To the lowest floor

| Basic Intermediate Advanced Administrator | keypad PC M2CS | Controller Car | Hydraulic Traction |

02.08 – Car restriction

Allows to restrict the use of the elevator if necessary

02.08.01 - Temporal call restrictions

Disables all the calls temporarily

If a call is made by the hand held console, the lift will travel to the floor but the door will not be opened

The function is temporal, it means that, if this parameter is set to 0, or if the power is turned off and on again or after an hour, the calls will be available again

| Basic Intermediate Advanced Administrator | keypad PC M2CS | Controller Car | Hydraulic Traction |

02.08.02 - Input for disable all calls

If this input is activated, the lift will not accept new calls.

Only new hand Held console/PC/M2CS calls will be accepted

| Basic Intermediate Advanced Administrator | keypad PC M2CS | Controller Car | Hydraulic Traction |

02.08.10 - Auxiliar input to set out of service

Allows to set the lift out of service by an external input.

This input is closed during normal operation and opens when the lift needs to be out of service

NOTE: If the lift is traveling, the out of service will occur when stops and open the doors

| Basic Intermediate Advanced Administrator | keypad PC M2CS | Controller Car | Hydraulic Traction |

02.08.30 - Floor restrictions

Allows to restrict a floor by an input

If the input is closed, the floor is available. If it is open the floor is restricted

| Basic Intermediate Advanced Administrator | keypad PC M2CS | Controller Car | Hydraulic Traction |

02.08.30.01 - 02.08.30.23 -restrictions floor 0 – floor 22

| Basic Intermediate Advanced Administrator | keypad PC M2CS | Controller Car | Hydraulic Traction |

02.10 - Specific options of the installation

Setting up the specific functions of the installation

02.10.01 - Evacuation control in case of fire (EN81-73)

Setting of the parameters related with evacuation in case of fire

| Basic Intermediate Advanced Administrator | keypad PC M2CS | Controller Car | Hydraulic Traction |

02.10.01.01 - EN81-73 operative

Set if the lift has EN81-73 operative or not

0 - EN81-73 operative disabled

1 - EN81-73 operative enabled

FACTORY DEFAULT: 0

| Basic Intermediate Advanced Administrator | keypad PC M2CS | Controller Car | Hydraulic Traction |

02.10.01.02 - Main evacuation floor

Sets the evacuation floor where the lift will go in case of main evacuation signal detected

FACTORY DEFAULT: 0

MIN: 0

MAX: 31

STEP: 1

| Basic Intermediate Advanced Administrator | keypad PC M2CS | Controller Car | Hydraulic Traction |

02.10.01.03 - Door to open on main evacuation floor

Defines the door to open on main evacuation floor in the event a main evacuation signal is detected

1 - Open door 1

2 - Open door 2

1 and 2 - Open both doors. (A and B on door operator configuration of this floor must be checked)

NOTE: It possible to open one door in normal operation, and the other one on evacuation mode. To do this, the door configuration of this floor should be selective entrance (A, B and E checked). FACTORY DEFAULT: 1

| Basic Intermediate Advanced Administrator | keypad PC M2CS | Controller Car | Hydraulic Traction |

02.10.01.04 - Main alarm signal

Defines where EN81-73 main alarm signal is connected

FACTORY DEFAULT: Not assigned

| Basic Intermediate Advanced Administrator | keypad PC M2CS | Controller Car | Hydraulic Traction |

02.10.01.05 - Do not enter sign on main evacuation floor

Defines where the 'do not enter' sign (EN81-73), for main evacuation floor, is connected to

FACTORY DEFAULT: Not assigned

| Basic Intermediate Advanced Administrator | keypad PC M2CS | Controller Car | Hydraulic Traction |

02.10.01.06 - Alternative evacuation floor

Sets the evacuation floor where the lift will go in the event an alternative evacuation signal is detected

FACTORY DEFAULT: 1

MIN: 0

MAX: 31

STEP: 1

| **Basic** Intermediate Advanced Administrator | keypad PC M2CS | Controller Car | Hydraulic Traction |

02.10.01.07 - Door to open on alternative evacuation floor

Defines the door to open on alternative evacuation floor in the event an alternative evacuation signal is detected

1 - Open door 1

2 - Open door 2

1 and 2 - Open both doors. (A and B on door operator configuration of this floor must be checked)

NOTE: It possible to open one door in normal operation, and the other one on evacuation mode. To do this, the door configuration of this floor should be selective entrance (A, B and E checked). FACTORY DEFAULT: 1

| **Basic** Intermediate Advanced Administrator | keypad PC M2CS | Controller Car | Hydraulic Traction |

02.10.01.08 - Alternative alarm signal

Defines where the EN81-73 alternative alarm signal is connected to

FACTORY DEFAULT: Not assigned

| **Basic** Intermediate Advanced Administrator | keypad PC M2CS | Controller Car | Hydraulic Traction |

02.10.01.09 - Do not enter sign on alternative evacuation floor

Defines where the (EN81-73)'do not enter' sign, on alternative evacuation floor, is connected to

FACTORY DEFAULT: Not assigned

| **Basic** Intermediate Advanced Administrator | keypad PC M2CS | Controller Car | Hydraulic Traction |

02.10.01.20 - Close doors at evacuation floor

Allows to set the doors rest state on evacuation floor.

0 - The doors remain open

1 - The doors remain closed

| **Basic** Intermediate Advanced Administrator | keypad PC M2CS | Controller Car | Hydraulic Traction |

02.10.01.21 - VIP enabled in case or alarm

Allows or not the VIP keyswitch under alarm

0 - VIP is not allowed

1 - VIP is allowed

| **Basic** Intermediate Advanced Administrator | keypad PC M2CS | Controller Car | Hydraulic Traction |

02.10.05 - EN81-20 cotrol

EN81-20 related parameters

| **Basic** Intermediate Advanced Administrator | keypad PC M2CS | Controller Car | Hydraulic Traction |

02.10.05.01 - Enable EN81-20

Enables the EN81-20 operation

0 - Disabled

1 - Enabled

| **Basic** Intermediate Advanced Administrator | keypad PC M2CS | Controller Car | Hydraulic Traction |

02.10.05.10 - Output to indicate movement with chain bridged

Output to connect an acoustic and light signal to indicate that the lift is moving with a bridge on any chain

| Basic Intermediate Advanced Administrator | keypad PC M2CS | Controller Car | Hydraulic Traction |

02.10.10 - Control of the speed governor blocking system (A3)

Setting of the parameters related with the speed governor blocking system

| Basic Intermediate Advanced Administrator | keypad PC M2CS | Controller Car | Hydraulic Traction |

02.10.10.01 - Speed governor blocking system

Selects whether, or not, the speed governor has a blocking system that prevents out of control movements. In affirmative case, Hidra Crono needs to check if it is unblocked before any movement

0 - The speed governor does NOT have a blocking system

1 - The speed governor HAS a blocking system and Hidra Crono needs to check if is unblocked in order to make any movement.

FACTORY DEFAULT: 1

| Basic Intermediate Advanced Administrator | keypad PC M2CS | Controller Car | Hydraulic Traction |

02.10.10.02 - Speed governor unlocked signal

Defines where the unlocked signal of speed governor is connected to. Hidra Crono needs to check this unlocked signal as a condition to move the car. This signal is required only if the speed governor has a locking system.

FACTORY DEFAULT: Not assigned

| Basic Intermediate Advanced Administrator | keypad PC M2CS | Controller Car | Hydraulic Traction |

02.10.10.03 - Speed governor unlocking control

Defines where the unlocking speed governor output signal is connected to. This signal is required only if the speed governor has a locking system.

FACTORY DEFAULT: Not assigned

| Basic Intermediate Advanced Administrator | keypad PC M2CS | Controller Car | Hydraulic Traction |

02.10.10.04 - Maximum number of errors allowed on speed governor blocking system

Set the maximum number of consecutive errors to consider speed governor locking system failure.

FACTORY DEFAULT: 1

MIN: 1 / MAX: 250

| Basic Intermediate Advanced Administrator | keypad PC M2CS | Controller Car | Hydraulic Traction |

02.10.11 - Brake contacts Monitor system (A3)

Setting of the parameters related to the brake contact monitoring system

| Basic Intermediate Advanced Administrator | keypad PC M2CS | Controller Car | Hydraulic Traction |

02.10.11.01 - Brake contacts Monitors enable

Selects whether the controller must check the brake contacts

0 - Does not have to monitor the brake contacts

1 - Has to monitor the brake contacts

FACTORY DEFAULT: 1

| Basic Intermediate Advanced Administrator | keypad PC M2CS | Controller Car | Hydraulic Traction |

02.10.11.02 - Brake contact 1 (1 of 2)

Defines where brake contact 1 is connected to

FACTORY DEFAULT: Not assigned

| Basic Intermediate Advanced Administrator | keypad PC M2CS | Controller Car | Hydraulic Traction |

02.10.11.03 - Brake contact 2 (2 of 2)

Defines where brake contact 2 is connected to

FACTORY DEFAULT: Not assigned

| Basic Intermediate Advanced Administrator | keypad PC M2CS | Controller Car | Hydraulic Traction |

02.10.11.04 - Maximum number of errors allowed on brake monitor

Set the maximum number of consecutive errors to consider brake fault.

FACTORY DEFAULT: 1

MIN: 1

MAX: 250

STEP: 1

| Basic Intermediate Advanced Administrator | keypad PC M2CS | Controller Car | Hydraulic Traction |

02.10.15 - Function of automatic entering Inspection Mode

Adjustment of the parameters related with, automatic entering, inspection mode

| Basic Intermediate Advanced Administrator | keypad PC M2CS | Controller Car | Hydraulic Traction |

02.10.15.01 - Enable the automatic entering under Inspection

Enable the function of, automatic entering, inspection mode. (When a sensor located on the car top detects the access, the controller automatically enters *Inspection Mode* even if the car top selector is in NORMAL mode)

If this operation is enabled, in order to leave Inspection Mode is necessary to enter a command using a signal in the controller or via PC/handheld terminal.

0 – Without automatic entering in inspection mode

1 – With automatic entering in inspection mode, when a car top access is detected

FACTORY DEFAULT: 0

| Basic Intermediate Advanced Administrator | keypad PC M2CS | Controller Car | Hydraulic Traction |

02.10.15.02 - Signal to detect shaft access

Input used to detect shaft access

FACTORY DEFAULT: Not assigned

| Basic Intermediate Advanced Administrator | keypad PC M2CS | Controller Car | Hydraulic Traction |

02.10.15.04 - Permission to leave Inspection Mode

Allows the controller to leave Inspection Mode

NOTE: This input only works if the selector is in NORMAL mode and the safety circuit is closed

| Basic Intermediate Advanced Administrator | keypad PC M2CS | Controller Car | Hydraulic Traction |

02.10.15.10 - Resume normal operation after inspection

Defines an output to generate a pulse to the coils that allow resuming normal operation after inspection (EN81-21)

FACTORY DEFAULT: Not assigned

| Basic Intermediate Advanced Administrator | keypad PC M2CS | Controller Car | Hydraulic Traction |

02.10.15.11 - Signal to detect shaft access

Input used to detect shaft access

| **Basic** Intermediate Advanced Administrator | keypad PC M2CS | Controller Car | Hydraulic Traction |

02.10.15.12 - Resume normal operation after inspection

Defines an output to generate a pulse to the coils that allow resuming normal operation after inspection (EN81-21)

| **Basic** Intermediate Advanced Administrator | keypad PC M2CS | Controller Car | Hydraulic Traction |

02.12 - SPS configuration

Sets the configuration parameters of the SPS

| **Basic** Intermediate Advanced Administrator | keypad PC M2CS | Controller Car | Hydraulic Traction |

02.12.01 – Floor distribution

Floor distribution

A - Number of floor below CVI signal

B - Number of floors between CVI and CVS signals

C - Number of floors above CVS signal

FACTORY DEFAULT: 1 0 1 0 0 0

| **Basic** Intermediate Advanced Administrator | keypad PC M2CS | Controller Car | Hydraulic Traction |

02.12.10 – Encoder model

Encoder model selection

FACTORY DEFAULT: Wach SilentMove

| **Basic** Intermediate Advanced Administrator | keypad PC M2CS | Controller Car | Hydraulic Traction |

02.12.11 – Encoder direction

Encoder rotation direction

FACTORY DEFAULT: CW

| **Basic** Intermediate Advanced Administrator | keypad PC M2CS | Controller Car | Hydraulic Traction |

02.12.20 – Lift nominal speed

Sets the lift nominal speed (m/s)

FACTORY DEFAULT: 1.0

| **Basic** Intermediate Advanced Administrator | keypad PC M2CS | Controller Car | Hydraulic Traction |

02.12.21 – Machine nominal speed

Sets the machine nominal speed (m/s)

FACTORY DEFAULT: 1.0

| **Basic** Intermediate Advanced Administrator | keypad PC M2CS | Controller Car | Hydraulic Traction |

02.12.30 – Inverter type

Sets the inverter type

FACTORY DEFAULT: FUJI

| **Basic** Intermediate Advanced Administrator | keypad PC M2CS | Controller Car | Hydraulic Traction |

02.12.31 – FUJI parameters

Sets the Fuji inverter parameters

| **Basic** Intermediate Advanced Administrator | keypad PC M2CS | Controller Car | Hydraulic Traction |

02.12.31.01 – L19 parameter

Set the value of L19 inverter parameter

FACTORY DEFAULT: 20

MIN: 20

MAX: 50

STEP: 1

| **Basic** Intermediate Advanced Administrator | keypad PC M2CS | Controller Car | Hydraulic Traction |

02.12.31.02 – L24 parameter

Set the value of L24 inverter parameter

FACTORY DEFAULT: 20

MIN: 20

MAX: 50

STEP: 1

| **Basic** Intermediate Advanced Administrator | keypad PC M2CS | Controller Car | Hydraulic Traction |

02.12.31.03 – L25 parameter

Set the value of L25 inverter parameter

FACTORY DEFAULT: 20

MIN: 10

MAX: 30

STEP: 1

| **Basic** Intermediate Advanced Administrator | keypad PC M2CS | Controller Car | Hydraulic Traction |

02.12.31.04 – L26 parameter

Set the value of L26 inverter parameter

FACTORY DEFAULT: 20

MIN: 10

MAX: 30

STEP: 1

| **Basic** Intermediate Advanced Administrator | keypad PC M2CS | Controller Car | Hydraulic Traction |

02.12.31.05 – E12 parameter

Set the value of E12 inverter parameter

FACTORY DEFAULT: 2.2s

| **Basic** Intermediate Advanced Administrator | keypad PC M2CS | Controller Car | Hydraulic Traction |

02.12.31.06 – E13 parameter

Set the value of E13 inverter parameter

FACTORY DEFAULT: 1.7s

| **Basic** Intermediate Advanced Administrator | keypad PC M2CS | Controller Car | Hydraulic Traction |

02.12.32 – Control Techniques parameters

Sets the Control Techniques inverter parameters

| **Basic** Intermediate Advanced Administrator | keypad PC M2CS | Controller Car | Hydraulic Traction |

02.12.32.01 – 1914/A35 parameter

Set the value of 1914 inverter parameter

FACTORY DEFAULT: 400

| Basic Intermediate **Advanced** Administrator | keypad PC M2CS | Controller Car | Hydraulic Traction |

02.12.32.02 – 1915/A36, A37, A38 parameter

Set the value of 1915 inverter parameter

FACTORY DEFAULT: 650

| Basic Intermediate **Advanced** Administrator | keypad PC M2CS | Controller Car | Hydraulic Traction |

02.12.32.03 – 0211/A40 parameter

Set the value of 0211 inverter parameter

FACTORY DEFAULT: 0.50

| Basic Intermediate **Advanced** Administrator | keypad PC M2CS | Controller Car | Hydraulic Traction |

02.12.32.04 – 0221/A41 parameter

Set the value of 0221 inverter parameter

FACTORY DEFAULT: 0.75

| Basic Intermediate **Advanced** Administrator | keypad PC M2CS | Controller Car | Hydraulic Traction |

02.12.50 – Advanced configuration

SPS advanced configuration

NOTE: Changing these parameters may cause lift malfunction

| Basic Intermediate **Advanced** Administrator | keypad PC M2CS | Controller Car | Hydraulic Traction |

02.12.50.01 – ZD magnet correction

Uses the ZD magnet to correct or not the lift position

0 - ZD magnet correction disabled

1 - ZD correction enabled

NOTE: ZD correction is not necessary in most cases. FACTORY DEFAULT: 0

| Basic Intermediate **Advanced** Administrator | keypad PC M2CS | Controller Car | Hydraulic Traction |

02.12.50.16 – Distance required for movement detection

Sets the required tripped distance (in millimeters) to decide the trip has started

NOTE: Modify this parameter to a lower value only if in the installation has a floor less than 500mm

| Basic Intermediate **Advanced** Administrator | keypad PC M2CS | Controller Car | Hydraulic Traction |

02.12.50.17 – Short floor distance

Below of this distance (in centimeters) the system will not calculate dynamically the point of the slowing speed signal and when the car leaves a floor the approach speed is set

NOTE: Increase the factory value only in the case of a short floor where the lift is not be able to stop on the correct level

| Basic Intermediate **Advanced** Administrator | keypad PC M2CS | Controller Car | Hydraulic Traction |

02.12.50.25 – short floors speed change adjustment factor

Allows anticipate speed change on short floors if it is required to travel some distance at approach speed

| Basic Intermediate **Advanced** Administrator | keypad PC M2CS | Controller Car | Hydraulic Traction |

02.12.50.30 – Speed change adjustment factor

Allows anticipate speed change if it is required to travel some distance at approach speed

FACTORY DEFAULT: 6

MIN: 0

MAX: 50

STEP: 1

| **Basic** Intermediate Advanced Administrator | keypad PC M2CS | Controller Car | Hydraulic Traction |

02.12.50.35 – Percentage of overspeed allowed on deceleration

Sets the percentage of overspeed allowed during deceleration

A wrong adjust of this parameter may cause a malfunction of this feature

If this percentage is too low, the lift may fault by overspeed even on correct trips

If this percentage is too high, an overspeed could be not detected

With the factory default, this protection in most of cases works correctly, but in some cases may be too much restrictive causing overspeed faults on correct trips. If this is the case, increase this parameter slightly until no errors occurs

| **Basic** Intermediate Advanced Administrator | keypad PC M2CS | Controller Car | Hydraulic Traction |

02.13 – SPS2 configuration

Sets the configuration parameters of the SPS

| **Basic** Intermediate Advanced Administrator | keypad PC M2CS | Controller Car | Hydraulic Traction |

02.13.01 – Floor distribution

Floor distribution

A - Number of floor below CVI signal

B - Number of floors between CVI and CVS signals

C - Number of floors above CVS signal

FACTORY DEFAULT: 1 0 1 0 0 0 0

| **Basic** Intermediate Advanced Administrator | keypad PC M2CS | Controller Car | Hydraulic Traction |

02.13.10 – Floors adjustment

Allows to set the level of each floor (in millimeters)

| **Basic** Intermediate Advanced Administrator | keypad PC M2CS | Controller Car | Hydraulic Traction |

02.13.10.01 - 02.13.10.32 Level of floor 0 to Level of floor31

| **Basic** Intermediate Advanced Administrator | keypad PC M2CS | Controller Car | Hydraulic Traction |

02.13.20 – floor zone distances

Set the floor zone distances (in mm)

| **Basic** Intermediate Advanced Administrator | keypad PC M2CS | Controller Car | Hydraulic Traction |

02.13.20.01 - advanced door opening distance

Modifies the distance at which the controller start to open doors

| **Basic** Intermediate Advanced Administrator | keypad PC M2CS | Controller Car | Hydraulic Traction |

02.13.20.10 - Distance required to stop going down

Displays the distance required for the upward stop

| **Basic** Intermediate Advanced Administrator | keypad PC M2CS | Controller Car | Hydraulic Traction |

02.13.20.15 - Distance required to stop going up

Displays the distance required for the downward stop

| **Basic** Intermediate Advanced Administrator | keypad PC M2CS | Controller Car | Hydraulic Traction |

02.13.40 – Smax settings

Set the parameters related with the maximum speed

| **Basic** Intermediate Advanced Administrator | keypad PC M2CS | Controller Car | Hydraulic Traction |

02.13.40.01 - Smax speed

If required, allows to modify the maximum speed (in mm/s)

| **Basic** Intermediate Advanced Administrator | keypad PC M2CS | Controller Car | Hydraulic Traction |

02.13.40.10 - UP dec. Smax

Deceleration distance going up

| **Basic** Intermediate Advanced Administrator | keypad PC M2CS | Controller Car | Hydraulic Traction |

02.13.40.11 - DOWN dec. Smax

Deceleration distance going down

| **Basic** Intermediate Advanced Administrator | keypad PC M2CS | Controller Car | Hydraulic Traction |

02.13.40.20 - Up acc. Smax

Acceleration distance going up

| **Basic** Intermediate Advanced Administrator | keypad PC M2CS | Controller Car | Hydraulic Traction |

02.13.40.21 - DOWN acc. Smax

Acceleration distance going down

| **Basic** Intermediate Advanced Administrator | keypad PC M2CS | Controller Car | Hydraulic Traction |

02.13.40.90 - Smax disable

Temporarily turns off the maximum speed to adjust slower speeds

| **Basic** Intermediate Advanced Administrator | keypad PC M2CS | Controller Car | Hydraulic Traction |

02.13.41 – Smed settings

Set the parameters related with the medium speed

| **Basic** Intermediate Advanced Administrator | keypad PC M2CS | Controller Car | Hydraulic Traction |

02.13.41.01 - Smed speed

If required, allows to modify the medium speed (in mm/s)

NOTE: Smed must be faster than Smin and slower than Smax

| **Basic** Intermediate Advanced Administrator | keypad PC M2CS | Controller Car | Hydraulic Traction |

02.13.41.10 - UP dec. Smed

Deceleration distance going up

| **Basic** Intermediate Advanced Administrator | keypad PC M2CS | Controller Car | Hydraulic Traction |

02.13.41.11 - DOWN dec. Smed

Deceleration distance going down

| **Basic** **Intermediate** **Advanced** **Administrator** | keypad PC M2CS | Controller Car | Hydraulic Traction |

02.13.41.20 - Up acc. Smed

Acceleration distance going up

| **Basic** **Intermediate** **Advanced** **Administrator** | keypad PC M2CS | Controller Car | Hydraulic Traction |

02.13.41.21 - DOWN acc. Smed

Acceleration distance going down

| **Basic** **Intermediate** **Advanced** **Administrator** | keypad PC M2CS | Controller Car | Hydraulic Traction |

02.13.41.90 - Smed disable

Temporarily turns off the medium speed to adjust slower speeds

| **Basic** **Intermediate** **Advanced** **Administrator** | keypad PC M2CS | Controller Car | Hydraulic Traction |

02.13.42 – Smin settings

Set the parameters related with the minimum speed

| **Basic** **Intermediate** **Advanced** **Administrator** | keypad PC M2CS | Controller Car | Hydraulic Traction |

02.13.42.01 -Smin speed

If required, allows to modify the minimum speed (in mm/s)

NOTE: Smin must be slower than Smed

| **Basic** **Intermediate** **Advanced** **Administrator** | keypad PC M2CS | Controller Car | Hydraulic Traction |

02.13.42.10 -UP dec. Smin

Deceleration distance going up

| **Basic** **Intermediate** **Advanced** **Administrator** | keypad PC M2CS | Controller Car | Hydraulic Traction |

02.13.42.11 -DOWN dec. Smin

Deceleration distance going down

| **Basic** **Intermediate** **Advanced** **Administrator** | keypad PC M2CS | Controller Car | Hydraulic Traction |

02.13.42.20 -Up acc. Smin

Acceleration distance going up

| **Basic** **Intermediate** **Advanced** **Administrator** | keypad PC M2CS | Controller Car | Hydraulic Traction |

02.13.42.21 -DOWN acc. Smin

Acceleration distance going down

| **Basic** **Intermediate** **Advanced** **Administrator** | keypad PC M2CS | Controller Car | Hydraulic Traction |

02.13.42.90 -Smin disable

Temporarily turns off the minimum speed to adjust slower speeds

| **Basic** **Intermediate** **Advanced** **Administrator** | keypad PC M2CS | Controller Car | Hydraulic Traction |

02.13.90 – SPS2 advanced parameters

| Basic Intermediate Advanced Administrator | keypad PC M2CS | Controller Car | Hydraulic Traction |

02.15 - Maintenance

Allow to perform maintenance operations

02.15.01 - Test

Setting of the parameters related with the lift test mode

| Basic Intermediate Advanced Administrator | keypad PC M2CS | Controller Car | Hydraulic Traction |

02.15.01.01 - Test mode enable

Enables or disables test mode. This mode allows testing to all the elements of the complete installation

0 - Test mode disabled

1 - Test mode enabled

NOTE: While the lift is under test mode is able to accept new calls. If it's doing a test travel and a call is made, the car aborts the test travel and will change to normal mode. After that, will return to test mode. FACTORY DEFAULT: 0

| Basic Intermediate Advanced Administrator | keypad PC M2CS | Controller Car | Hydraulic Traction |

02.15.01.02 - Test mode behavior

Set between the different modes of tests mode operation

0 - The car travels to random floors

1 - The car travels from limit to limit

FACTORY DEFAULT: 0

| Basic Intermediate Advanced Administrator | keypad PC M2CS | Controller Car | Hydraulic Traction |

02.15.01.03 - Doors operation under test mode

Sets the behavior of the doors on every stop under test mode

0 - The doors have no activity on every test stop

1 - The doors open and close on every test stop

NOTE: the doors open/close operation are floor dependent of the configuration of each floor. FACTORY DEFAULT: 1

| Basic Intermediate Advanced Administrator | keypad PC M2CS | Controller Car | Hydraulic Traction |

02.15.01.04 - Waiting time between test travels

Set the time to wait between test travels

NOTE: Adjust this parameter to 0 s to make another test travel when stop time finishes. FACTORY DEFAULT: 0 s

ATTENTION!!! Set this time high enough to ensure that maximum number of connection per hour of the machine is not exceed.

| Basic Intermediate Advanced Administrator | keypad PC M2CS | Controller Car | Hydraulic Traction |

02.15.05 - Speed governor test

Generate a pulse in the trigger coil of the speed governor. It can control speed governors with up to three different coils.

| Basic Intermediate Advanced Administrator | keypad PC M2CS | Controller Car | Hydraulic Traction |

02.15.05.01 - Output for the coil 1

Sets the output where the speed governor - coil 1, is connected to

FACTORY DEFAULT: Not assigned

| Basic Intermediate Advanced Administrator | keypad PC M2CS | Controller Car | Hydraulic Traction |

02.15.05.02 - Coil 1 pulse

Generates a one second pulse to coil 1 of the speed governor

| Basic Intermediate Advanced Administrator | keypad PC M2CS | Controller Car | Hydraulic Traction |

02.15.05.03 - Output for the coil 2

Sets the output where the speed governor - coil 2, is connected to

FACTORY DEFAULT: Not assigned

| Basic Intermediate Advanced Administrator | keypad PC M2CS | Controller Car | Hydraulic Traction |

02.15.05.04 - Coil 2 pulse

Generates a one second pulse to coil 2 of the speed governor

| Basic Intermediate Advanced Administrator | keypad PC M2CS | Controller Car | Hydraulic Traction |

02.15.05.05 - Output for the coil 3

Sets the output where the speed governor - coil 3, is connected to

FACTORY DEFAULT: Not assigned

| Basic Intermediate Advanced Administrator | keypad PC M2CS | Controller Car | Hydraulic Traction |

02.15.05.06 - Coil 3 pulse

Generates a one second pulse to coil 3 of the speed governor

| Basic Intermediate Advanced Administrator | keypad PC M2CS | Controller Car | Hydraulic Traction |

02.15.10 - Final limit switch test

Tests the final limit switches. This command causes that the controller ignores the floor level and, subsequently, the lift will run over the final limit switches at low speed

| Basic Intermediate Advanced Administrator | keypad PC M2CS | Controller Car | Hydraulic Traction |

02.15.15 - UCM test

UCM test.

To make this test is required:

- Lift under public service and idle
- At floor level with doors opened
- Levelling enabled (parameter 02.04.10.01 set to 1)

NOTE: If the levelling is not required for this installation, set this parameter to 1 in order to make the UCM test ant when it is done reset to 0.

In order to make this test a CSG/DSG circuit is required in the controller

| Basic Intermediate Advanced Administrator | keypad PC M2CS | Controller Car | Hydraulic Traction |

02.15.15.01 - UCM test upwards

When this command is sent, the lift starts an up travel at nominal speed with doors opened. This trip allows to measure the distance travelled and check the UCM system.

| Basic Intermediate Advanced Administrator | keypad PC M2CS | Controller Car | Hydraulic Traction |

02.15.15.10 - UCM test downwards

When this command is sent, the lift starts a down travel at nominal speed with doors opened. This trip allows to measure the distance travelled and check the UCM system.

| Basic Intermediate Advanced Administrator | keypad PC M2CS | Controller Car | Hydraulic Traction |

02.15.20 - Brake test

Allows to make the brake test

| Basic Intermediate Advanced Administrator | keypad PC M2CS | Controller Car | Hydraulic Traction |

02.15.20.01 - Brake test command

This command makes an special travel to test the brakes

It is only active when the lift is idle with all the calls disabled by the input to disable calls.

Then send this command and make a call with the handheld console/PC

(The lift will start the travel and in the slowing down signal will stop suddenly)

| Basic Intermediate Advanced Administrator | keypad PC M2CS | Controller Car | Hydraulic Traction |

02.20 - Advanced Parameters

Setting of the advanced parameters

02.20.01 - Run time limit while on public service

Run time limit while on public service is the maximum time allowed to run, without detecting changes on the position signals. If this time is reached, the lift enters permanent out of service mode, that requires manual restart.

FACTORY DEFAULT: 45 s

| Basic Intermediate Advanced Administrator | keypad PC M2CS | Controller Car | Hydraulic Traction |

02.20.02 - Series filter

Adjust the necessary time with closed series to start a new travel. This timer has to be enough high to prevent false connections of the contactors

| Basic Intermediate Advanced Administrator | keypad PC M2CS | Controller Car | Hydraulic Traction |

02.20.03 - Machine room temperature sensor enabled

Enables or disables the integrated machine room temperature sensor

0 - Machine room temp sensor disabled

1 - Machine room temp sensor enabled

| Basic Intermediate Advanced Administrator | keypad PC M2CS | Controller Car | Hydraulic Traction |

02.20.04 - Minimum environment temperature allowed

Select the minimum machine room environment temperature allowed. Below this limit, the lift operation will be inhibited

NOTE: This parameter is valid only if machine room temp sensor is enabled. FACTORY DEFAULT: 4° C ~ 5° C

| Basic Intermediate Advanced Administrator | keypad PC M2CS | Controller Car | Hydraulic Traction |

02.20.05 - Maximum environment temperature allowed

Select the maximum machine room environment temperature allowed. Above this limit, the lift operation will be inhibited

NOTE: This parameter is valid only if machine room temp sensor is enabled. FACTORY DEFAULT: 45° C ~ 46° C

| Basic Intermediate Advanced Administrator | keypad PC M2CS | Controller Car | Hydraulic Traction |

02.20.07 - Photocell configuration

Set the photocell type

0 - (NC) without photocell obstruction, there is voltage at the input

1 - (NO) without photocell obstruction, there is no voltage at the input

| Basic Intermediate Advanced Administrator | keypad PC M2CS | Controller Car | Hydraulic Traction |

02.20.08 - Overload detector configuration

Set the overload detector configuration

0 - (NC) without overload, there is voltage at the input

1 - (NO) without overload, there is no voltage at the input

FACTORY DEFAULT: 0

| **Basic** Intermediate Advanced Administrator | keypad PC M2CS | Controller Car | Hydraulic Traction |

02.20.09 - False calls cancelling

If the number of stops set on this parameter occurs, the manual landing doors have not been open and the photocell has not been intercepted, the car calls will be erased

NOTE: Set this parameter to OFF to disable this function. FACTORY DEFAULT: 4

| **Basic** Intermediate Advanced Administrator | keypad PC M2CS | Controller Car | Hydraulic Traction |

02.20.10 - Magnets Table

Setting of the magnets table required only in special installations

| **Basic** Intermediate Advanced Administrator | keypad PC M2CS | Controller Car | Hydraulic Traction |

02.20.10.01 - 02.20.10.32 From Floor 0 magnet data to Floor 31 magnet data

Each floor, magnet information

	A B C D E F G
FACTORY DEFAULT Floor 0	2 0 1 0 0 0 0
FACTORY DEFAULT Floor 1	0 1 0 0 0 0 0
FACTORY DEFAULT Floor 2	0 0 0 0 0 0 0
FACTORY DEFAULT Floor 3	0 0 0 0 0 0 0
FACTORY DEFAULT Floor 4	0 0 0 0 0 0 0
FACTORY DEFAULT Floor 5	0 0 0 0 0 0 0
FACTORY DEFAULT Floor 6	0 0 0 0 0 0 0
FACTORY DEFAULT Floor 7	0 0 0 0 0 0 0
FACTORY DEFAULT Floor 8	0 0 0 0 0 0 0
FACTORY DEFAULT Floor 9	0 0 0 0 0 0 0
FACTORY DEFAULT Floor 10	0 0 0 0 0 0 0
FACTORY DEFAULT Floor 11	0 0 0 0 0 0 0
FACTORY DEFAULT Floor 12	0 0 0 0 0 0 0
FACTORY DEFAULT Floor 13	0 0 0 0 0 0 0
FACTORY DEFAULT Floor 14	0 0 0 0 0 0 0
FACTORY DEFAULT Floor 15	0 0 0 0 0 0 0
FACTORY DEFAULT Floor 16	0 0 0 0 0 0 0
FACTORY DEFAULT Floor 17	0 0 0 0 0 0 0
FACTORY DEFAULT Floor 18	0 0 0 0 0 0 0
FACTORY DEFAULT Floor 19	0 0 0 0 0 0 0
FACTORY DEFAULT Floor 20	0 0 0 0 0 0 0
FACTORY DEFAULT Floor 21	0 0 0 0 0 0 0
FACTORY DEFAULT Floor 22	0 0 0 0 0 0 0
FACTORY DEFAULT Floor 23	0 0 0 0 0 0 0
FACTORY DEFAULT Floor 24	0 0 0 0 0 0 0
FACTORY DEFAULT Floor 25	0 0 0 0 0 0 0
FACTORY DEFAULT Floor 26	0 0 0 0 0 0 0
FACTORY DEFAULT Floor 27	0 0 0 0 0 0 0
FACTORY DEFAULT Floor 28	0 0 0 0 0 0 0
FACTORY DEFAULT Floor 29	0 0 0 0 0 0 0
FACTORY DEFAULT Floor 30	0 0 0 0 0 0 0
FACTORY DEFAULT Floor 31	0 0 0 0 0 0 0

NOTE: This configuration is required only if positioning mode is set to MAN

| **Basic** Intermediate Advanced Administrator | keypad PC M2CS | Controller Car | Hydraulic Traction |

02.20.15 - Machine temperature sensor enabled (PTC)

Enables or disables the motor temperature control (PTC)

0 - Disabled

1 – Enabled

| Basic Intermediate **Advanced** Administrator | keypad PC M2CS | Controller Car | Hydraulic Traction |

02.20.16 - CAN fault tolerant mode

It allows the elevator work if some CAN errors occur

| Basic Intermediate **Advanced** Administrator | keypad PC M2CS | Controller Car | Hydraulic Traction |

02.20.20 - SSG broken requires manual restart

When safety circuit breaks, this parameter allow you to select if the lift restarts automatically when SSG closes or a manual operation is required in addition

0 - restarts Automatically

1 - Requires a manual operation

NOTE: the manual operation required may be, put the inspection selector ON & OFF, turn the power OFF & ON, or the restart command

| Basic Intermediate **Advanced** Administrator | keypad PC M2CS | Controller Car | Hydraulic Traction |

02.20.21 - Automatic leaving of inspection mode

Sets the behaviour of the lift when the inspection selector change to NORMAL

0 - The lift waits until the parameter 02.10.15.04 is sent to enter at public service

1 - Enters automatically under public service

| Basic Intermediate **Advanced** Administrator | keypad PC M2CS | Controller Car | Hydraulic Traction |

02.25 - Group

Parameter setting on lifts working in group

02.25.01 - Maximum number of lifts allowed in group

Sets the maximum number of lifts allowed to work on this group

| Basic Intermediate **Advanced** Administrator | keypad PC M2CS | Controller Car | Hydraulic Traction |

02.25.02 - Car identification

Car ID, within the group. Each car must have a unique identifier, for perfect operation

| Basic Intermediate **Advanced** Administrator | keypad PC M2CS | Controller Car | Hydraulic Traction |

02.25.10 - Number of floors of the group

Set the total number of floor of the group. On groups with asymmetrical shafts, this number must be the total number of floors served, even if some cars are disabled on some floors.

ATENCION: This parameter has to be the same value on each car of the group

EXAMPLE: In a group with 3 cars where cars 1 and 2 serves floor 0 to 7 and car 3 serves floors -1 to 7, this parameter has to be adjusted to 9 on the 3 cars

FACTORY DEFAULT: 2

MIN: 2, MAX: 32, STEP: 1

| Basic Intermediate **Advanced** Administrator | keypad PC M2CS | Controller Car | Hydraulic Traction |

02.25.11 - Number of floors of this car

Shows the number of floors served by this car

| Basic Intermediate **Advanced** Administrator | keypad PC M2CS | Controller Car | Hydraulic Traction |

02.25.12 - Number of bottom floors not served

Adjust the number of bottom floors, not served by this car

FACTORY DEFAULT: 0

MIN: 0, MAX: 7, STEP: 1

| Basic Intermediate **Advanced** Administrator | keypad PC M2CS | Controller Car | Hydraulic Traction |

02.25.13 - Number of top floors not served

Shows the number of top floors, not served by this car

| Basic Intermediate **Advanced** Administrator | keypad PC M2CS | Controller Car | Hydraulic Traction |

02.25.20 - Group behavior

Adjust the global behavior of the lift group

FAST: *Priority to collection in the shortest possible time. The system starts a resting car on any new call.*

ECO: *Priority to low consumption. The system starts a resting car only when a moving car has no possibility to serve a call within a short period*

BALANCED: *The system behavior balances between the two previous modes*

FACTORY DEFAULT: FAST

| Basic Intermediate **Advanced** Administrator | keypad PC M2CS | Controller Car | Hydraulic Traction |

02.25.21 - Car typology

Allow the differentiation of cars that, owed to its dimensions/shape/special features, can answer calls that others, within the group, can't (for example, a larger car that can accommodate a stretcher). It is possible to have up to 4 different types of cars inside the same group:

A - Calls made on a car of type A, may be served by ANY car of the group

B - Calls made on a car of type B, may be served by cars of type B only

C - Calls made on a car of type C, may be served by cars of type C only

D - Calls made on a car of type D, may be served by cars of type D only

NOTE: If there is no difference between cars, this parameter must be set to A. FACTORY DEFAULT: A

| Basic Intermediate **Advanced** Administrator | keypad PC M2CS | Controller Car | Hydraulic Traction |

02.40 - Car top signals

Allows configuration of the available car signals located on the car top interface

02.40.01 – Inspection Mode door open Pushbutton

Enables a pushbutton to open both doors while in inspection mode

FACTORY DEFAULT: Not assigned

| Basic Intermediate **Advanced** Administrator | keypad PC M2CS | Controller Car | Hydraulic Traction |

02.40.02 - Inspection Mode door close Pushbutton

Enables a pushbutton to close both doors while in inspection mode

ATTENTION: This function ignores the photocell. FACTORY DEFAULT: Not assigned

| Basic Intermediate **Advanced** Administrator | keypad PC M2CS | Controller Car | Hydraulic Traction |

02.40.03 – Auxiliary input for full load signal

Defines where is connected the full load signal in case that the specific car top input is not suitable. Set to Car TOP if the car top signal

FACTORY DEFAULT: Not assigned

| Basic Intermediate **Advanced** Administrator | keypad PC M2CS | Controller Car | Hydraulic Traction |

02.40.04 - Auxiliary input for overload signal

Defines where is connected the over load signal in case that the specific car top input is not suitable. Set to Car TOP if the car top signal is used

FACTORY DEFAULT: Not assigned

| Basic Intermediate Advanced Administrator | keypad PC M2CS | Controller Car | Hydraulic Traction |

02.40.50 - Signal to disable false alarm calls

Output signal to disable false alarm calls when the lift is working properly. The lift sets this signal when is working properly. When the lift does not take calls, this output is enabled.

NOTE: It is not necessary to define this signal when the lift has a SAR autodialer

FACTORY DEFAULT: Not assigned

| Basic Intermediate Advanced Administrator | keypad PC M2CS | Controller Car | Hydraulic Traction |

02.41 - Shaft signals

02.41.01 - Final limit switch signal

Informs to the controller that the limit switch is reached

NOTE: THIS CONTACT IS NOT THE SAFETY CONTACT. Is an additional contact that informs the controller that the limit switch is reached if this happen

| Basic Intermediate Advanced Administrator | keypad PC M2CS | Controller Car | Hydraulic Traction |

02.50 - Virtual Cables

Setting of the parameters related to virtual connections

02.50.01 - 02.50.32 From Virtual cable 0 to Virtual cable 31

Virtual cable. A virtual cable is defined when an input is linked with an output

NOTE: See Controller documentation for details about the inputs and outputs available.

FACTORY DEFAULT: INPUT - Not assigned / OUTPUT - Not assigned

| Basic Intermediate Advanced Administrator | keypad PC M2CS | Controller Car | Hydraulic Traction |

02.60 - LOG configuration

Sets the parameters related with the info stored onto the LOG

| Basic Intermediate Advanced Administrator | keypad PC M2CS | Controller Car | Hydraulic Traction |

02.60.01 - Store the positioning information into the log

With this parameter adjusted to 1, the positioning signals info will be saved into the LOG, this is useful to find positioning errors but increase the size of the file

| Basic Intermediate Advanced Administrator | keypad PC M2CS | Controller Car | Hydraulic Traction |

02.60.02 - Save the series status onto the LOG

| Basic Intermediate Advanced Administrator | keypad PC M2CS | Controller Car | Hydraulic Traction |

02.75 - User administration

Allows the management of access to the parameters menu of up to five different user profiles

| Basic Intermediate Advanced Administrator | keypad PC M2CS | Controller Car | Hydraulic Traction |

02.75.01 - User 1

User 1 access

| [Basic](#) [Intermediate](#) [Advanced](#) **Administrator** | [keypad](#) [PC](#) [M2CS](#) | [Controller](#) [Car](#) | [Hydraulic](#) [Traction](#) |

02.75.01.01 - PIN number

User 1 PIN number setting

| [Basic](#) [Intermediate](#) [Advanced](#) **Administrator** | [keypad](#) [PC](#) [M2CS](#) | [Controller](#) [Car](#) | [Hydraulic](#) [Traction](#) |

02.75.01.02 - Access level

User 1 access level

No access: without access

Basic: Basic access

Intermediate: Intermediate access

Advanced: Advanced Access

FACTORY DEFAULT: Basic

| [Basic](#) [Intermediate](#) [Advanced](#) **Administrator** | [keypad](#) [PC](#) [M2CS](#) | [Controller](#) [Car](#) | [Hydraulic](#) [Traction](#) |

02.75.02 - User 2

User 2 access

| [Basic](#) [Intermediate](#) [Advanced](#) **Administrator** | [keypad](#) [PC](#) [M2CS](#) | [Controller](#) [Car](#) | [Hydraulic](#) [Traction](#) |

02.75.02.01 - PIN number

User 2 PIN number setting

| [Basic](#) [Intermediate](#) [Advanced](#) **Administrator** | [keypad](#) [PC](#) [M2CS](#) | [Controller](#) [Car](#) | [Hydraulic](#) [Traction](#) |

02.75.02.02 - Access level

User 2 access level

No access: without access

Basic: Basic access

Intermediate: Intermediate access

Advanced: Advanced Access

FACTORY DEFAULT: No access

| [Basic](#) [Intermediate](#) [Advanced](#) **Administrator** | [keypad](#) [PC](#) [M2CS](#) | [Controller](#) [Car](#) | [Hydraulic](#) [Traction](#) |

02.75.03 - User 3

User 3 access

| [Basic](#) [Intermediate](#) [Advanced](#) **Administrator** | [keypad](#) [PC](#) [M2CS](#) | [Controller](#) [Car](#) | [Hydraulic](#) [Traction](#) |

02.75.03.01 - PIN number

User 3 PIN number setting

| [Basic](#) [Intermediate](#) [Advanced](#) **Administrator** | [keypad](#) [PC](#) [M2CS](#) | [Controller](#) [Car](#) | [Hydraulic](#) [Traction](#) |

02.75.03.02 - Access level

User 3 access level

No access: without access

Basic: Basic access

Intermediate: Intermediate access

Advanced: Advanced Access

FACTORY DEFAULT: No access

| **Basic** Intermediate Advanced Administrator | keypad PC M2CS | Controller Car | Hydraulic Traction |

02.75.04 - User 4

User 4 access

| **Basic** Intermediate Advanced Administrator | keypad PC M2CS | Controller Car | Hydraulic Traction |

02.75.04.01 - PIN number

User 4 PIN number setting

| **Basic** Intermediate Advanced Administrator | keypad PC M2CS | Controller Car | Hydraulic Traction |

02.75.04.02 - Access level

User 4 access level

No access: without access

Basic: Basic access

Intermediate: Intermediate access

Advanced: Advanced Access

FACTORY DEFAULT: No access

| **Basic** Intermediate Advanced Administrator | keypad PC M2CS | Controller Car | Hydraulic Traction |

02.75.05 - User 5

User 5 access

| **Basic** Intermediate Advanced Administrator | keypad PC M2CS | Controller Car | Hydraulic Traction |

02.75.05.01 - PIN number

User 5 PIN number setting

| **Basic** Intermediate Advanced Administrator | keypad PC M2CS | Controller Car | Hydraulic Traction |

02.75.05.02 - Access level

User 5 access level

No access: without access

Basic: Basic access

Intermediate: Intermediate access

Advanced: Advanced Access

FACTORY DEFAULT: No access

| **Basic** Intermediate Advanced Administrator | keypad PC M2CS | Controller Car | Hydraulic Traction |

02.75.90 - Administrator

Administrator setting

| **Basic** Intermediate Advanced Administrator | keypad PC M2CS | Controller Car | Hydraulic Traction |

02.75.90.01 - PIN number

Administrator PIN number setting

| **Basic** Intermediate Advanced **Administrator** | keypad PC M2CS | Controller Car | Hydraulic Traction |

03 - Tools

Allows maintenance operations of the lift

03.01 - Restart

Allow to restart the lift in case of permanent out of service that requires manual restart

| Basic Intermediate Advanced Administrator | keypad PC M2CS | Controller Car | Hydraulic Traction |

03.02 – Floor Call

Makes a car call to the selected floor

FACTORY DEFAULT: 0

MIN: 0

MAX: 31

STEP: 1

| Basic Intermediate Advanced Administrator | keypad PC M2CS | Controller Car | Hydraulic Traction |

03.05 - Partial trip counter

Partial trip counter, can be reset to 0

| Basic Intermediate Advanced Administrator | keypad PC M2CS | Controller Car | Hydraulic Traction |

03.05.01 - Partial trip counter value

Shows the value of the partial trip counter

| Basic Intermediate Advanced Administrator | keypad PC M2CS | Controller Car | Hydraulic Traction |

03.05.02 - Partial trip counter reset

Resets the value of the partial trip counter

| Basic Intermediate Advanced Administrator | keypad PC M2CS | Controller Car | Hydraulic Traction |

03.12 - SPS utilities

SPS utilities

| Basic Intermediate Advanced Administrator | keypad PC M2CS | Controller Car | Hydraulic Traction |

03.12.05 - Lower floor correction force

Allows to force a correction to floor 0

To force this correction, The car must be stopped and in public service. Then send this command and make any call

| Basic Intermediate Advanced Administrator | keypad PC M2CS | Controller Car | Hydraulic Traction |

03.12.10 - Learn installation

Allows start the learning process of the installation

This procedure requires an special operation to prevent an accidentally start

For details, see the SPS user manual

| Basic Intermediate Advanced Administrator | keypad PC M2CS | Controller Car | Hydraulic Traction |

03.12.20 - Floor level fine adjust

Allows increase or decrease the level of each floor independently

FACTORY DEFAULT: INPUT - FL-- / OUTPUT - 0mm

| Basic Intermediate Advanced Administrator | keypad PC M2CS | Controller Car | Hydraulic Traction |

03.12.30 - Floors adjustment

Allows to set the level of each floor (in millimeters)

| Basic Intermediate Advanced Administrator | keypad PC M2CS | Controller Car | Hydraulic Traction |

03.12.30.01 – 03.12.30.32 Lever of floor 0 to level of floor 31

| Basic Intermediate Advanced Administrator | keypad PC M2CS | Controller Car | Hydraulic Traction |

03.12.35 - Zone Adjustment

Sets the zones of each one of the floors (in millimeters)

A - distance for open doors when the car goes down (only for preopenig enabled)

B - distance for stop command when the car goes down

C - distance for stop command when the car goes up

D - distance for open doors when the car goes up (only for preopenig enabled)

| Basic Intermediate Advanced Administrator | keypad PC M2CS | Controller Car | Hydraulic Traction |

03.12.35.01 – 03.12.35.32 Floor 0 zone adjust to floor 31 zone adjust

| Basic Intermediate Advanced Administrator | keypad PC M2CS | Controller Car | Hydraulic Traction |

03.12.40 - SPS parameters save

Saves the SPS specific parameters onto the SPS

| Basic Intermediate Advanced Administrator | keypad PC M2CS | Controller Car | Hydraulic Traction |

03.12.90 - SPS factory defaults

Restores factory defaults of the SPS

Required for to start a learning process

| Basic Intermediate Advanced Administrator | keypad PC M2CS | Controller Car | Hydraulic Traction |

03.13 – SPS2 utilities

SPS utilities

| Basic Intermediate Advanced Administrator | keypad PC M2CS | Controller Car | Hydraulic Traction |

03.13.10 - Learn installation

Allows start the learning process of the installation

This procedure requires an special operation to prevent an accidentally start

For details, see the SPS user manual

| Basic Intermediate Advanced Administrator | keypad PC M2CS | Controller Car | Hydraulic Traction |

03.13.11 - speed learning

It allows to learn again the speeds if necessary. This is useful if, once the system is set up, the speeds are modified to different speeds than when the original learning was done.

When learn again the speeds, it is not necessary to set up the stop levels again.

The speeds learning process only starts when the elevator is at idle state with the doors closed and in a floor above the CVI

| Basic Intermediate Advanced Administrator | keypad PC M2CS | Controller Car | Hydraulic Traction |

03.13.40 - SPS parameters save

Saves the SPS specific parameters onto the SPS

| **Basic** Intermediate Advanced Administrator | keypad PC M2CS | Controller Car | Hydraulic Traction |

03.13.90 - SPS factory defaults

Restores factory defaults of the SPS

Required for to start a learning process

| **Basic** Intermediate Advanced Administrator | keypad PC M2CS | Controller Car | Hydraulic Traction |

03.50 - Date and time

Sets the date and time to store events with the correct timestamp

| **Basic** Intermediate Advanced Administrator | keypad PC M2CS | Controller Car | Hydraulic Traction |

03.50.01 - Week day

Sets the weekday

Sun - Sunday

Mon - Monday

Tue - Tuesday

Wed - Wednesday

Thu - Thursday

Fri - Friday

Sat - Saturday

FACTORY DEFAULT: Sun

| **Basic** Intermediate Advanced Administrator | keypad PC M2CS | Controller Car | Hydraulic Traction |

03.50.02 - Year

Sets the year

FACTORY DEFAULT: 12

MIN: 12

MAX: 99

STEP: 1

| **Basic** Intermediate Advanced Administrator | keypad PC M2CS | Controller Car | Hydraulic Traction |

03.50.03 - Month

Sets the Month

FACTORY DEFAULT: 1

MIN: 1

MAX: 12

STEP: 1

| **Basic** Intermediate Advanced Administrator | keypad PC M2CS | Controller Car | Hydraulic Traction |

03.50.04 - Day

Sets the day

FACTORY DEFAULT: 1

MIN: 1

MAX: 31

STEP: 1

| **Basic** Intermediate Advanced Administrator | keypad PC M2CS | Controller Car | Hydraulic Traction |

03.50.05 - Hour

Sets the hour

FACTORY DEFAULT: 0

MIN: 0

MAX: 23

STEP: 1

| **Basic** Intermediate Advanced Administrator | keypad PC M2CS | Controller Car | Hydraulic Traction |

03.50.06 - Minute

Sets the minute

FACTORY DEFAULT: 0

MIN: 0

MAX: 59

STEP: 1

| **Basic** Intermediate Advanced Administrator | keypad PC M2CS | Controller Car | Hydraulic Traction |

03.55 - Parameters

Setting of parameter related operations

| **Basic** Intermediate Advanced Administrator | keypad PC M2CS | Controller Car | Hydraulic Traction |

03.55.01 - Save parameters

Saves the parameters onto the controller memory

NOTE: Any change on the parameters unsaved, will be lost on a power fail

| **Basic** Intermediate Advanced Administrator | keypad PC M2CS | Controller Car | Hydraulic Traction |

03.55.10 - Restore factory defaults

Restore parameters to its factory defaults

NOTE: It is possible to restore the factory defaults only when the car is stopped with the safety circuit broken

| **Basic** Intermediate Advanced Administrator | keypad PC M2CS | Controller Car | Hydraulic Traction |

03.55.90 - Optional features access

Allow to access optional features

FACTORY DEFAULT: A - 1 / B - 0 / C - 0 / D - 0 / E - 0 / F - 0 / G - 0 / H - 0

| **Basic** Intermediate Advanced Administrator | keypad PC M2CS | Controller Car | Hydraulic Traction |

03.60 – Fault history

Utilities related to the fault history

| **Basic** Intermediate Advanced Administrator | keypad PC M2CS | Controller Car | Hydraulic Traction |

03.60.01 – Fault history reset

Deletes all the fault history records

| **Basic** Intermediate Advanced Administrator | keypad PC M2CS | Controller Car | Hydraulic Traction |

03.90 - Upgrade

Allows upgrade operations

| **Basic** Intermediate Advanced Administrator | keypad PC M2CS | Controller Car | Hydraulic Traction |

03.90.01 - Upgrade Controller Firmware

Allows the upgrade the controller firmware

In order to upgrade the firmware a micro SD card, with just one firmware file on the root, is required.

It is only possible to upgrade the firmware, on a lift with the safety circuit broken.

The upgrading process may take up to 5 minutes.

WARNING: Do not remove the micro SD card or power down the controller when the firmware upgrade is in progress.

NOTE: This operation must be made by qualified personal and under their own Responsibility

| [Basic](#) [Intermediate](#) [Advanced](#) [Administrator](#) | [keypad](#) [PC](#) [M2CS](#) | [Controller](#) [Car](#) | [Hydraulic](#) [Traction](#) |

Annexes and Examples

Annex 1. Inputs and outputs available for Hidra Crono

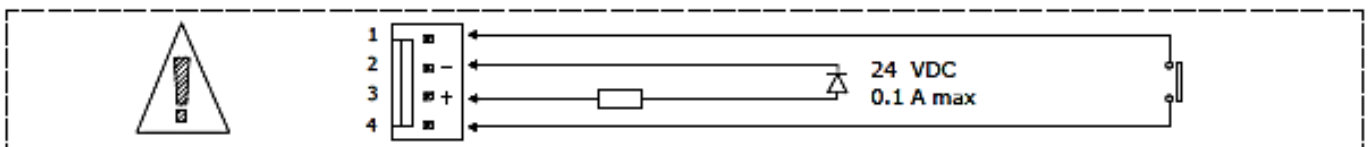
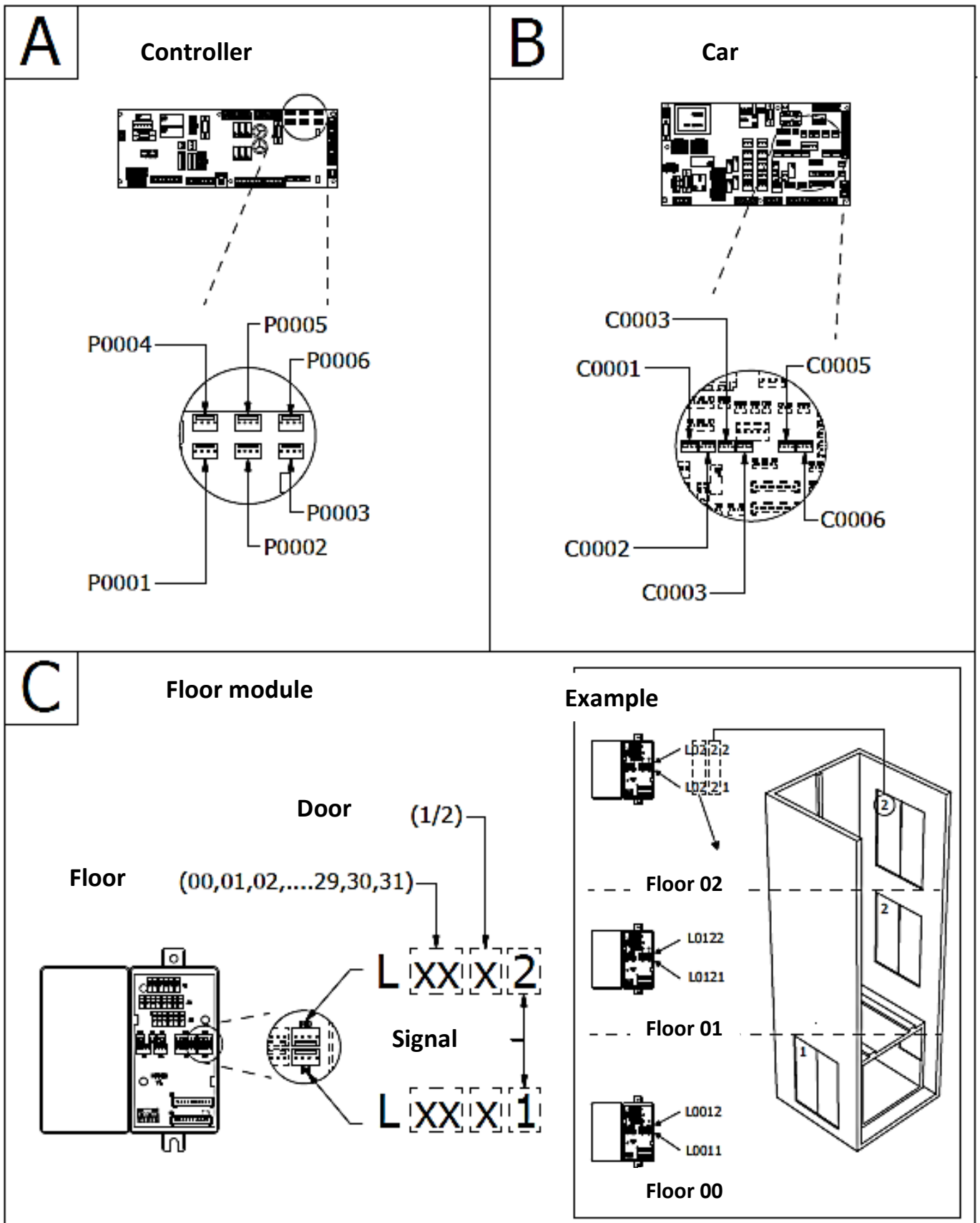

Example of menú settings

-If it is required to connect a fire signal in the FLOOR 01

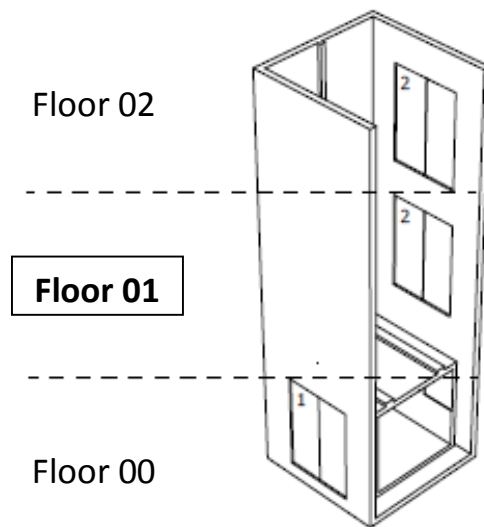

-It will be wired to the FLOOR 01 MP module that serves that door, **and it can be wired in any of the two possible inputs**

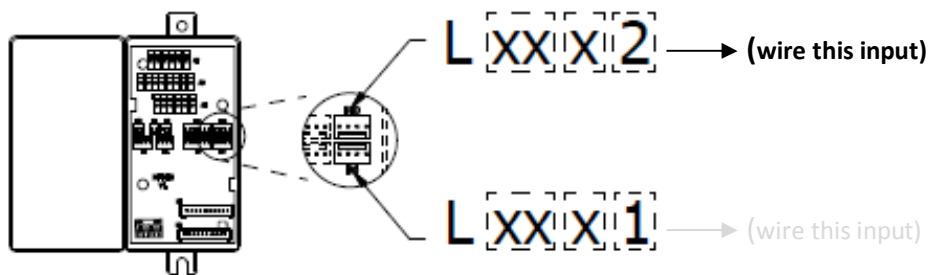

-Configure the setup menu to adjust the lift controller

02.10.01.04 – Main alarm signal

Defines where the main alarm signal EN81-73 is connected

Set...

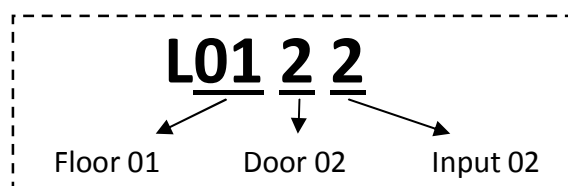



www.carlos-silva.com



C a r l o s S i l v a

Soluciones y Sistemas Electrónicos para Control de Ascensores
Electronic Lift Control Solutions & Systems
Lösungen und Elektronische Systeme zur Aufzugsteuerung Solutions et
Systèmes Électroniques pour Contrôle des Ascenseurs

Salvador Albert i Riera 3, 08339 Vilassar de Dalt, Barcelona, ESPAÑA

GPS: (41° 30q51+N. / 2° 22q12+E.)

Tel. +34 937 541 980 Fax +34 937 541 983

www.carlos-silva.com

e-mail: info@carlos-silva.com

Servicio Post-Venta (After-Sales Department) Tel: +34 937 541 981

e-mail: postventa@carlos-silva.com

DC81080Q01



ENG